

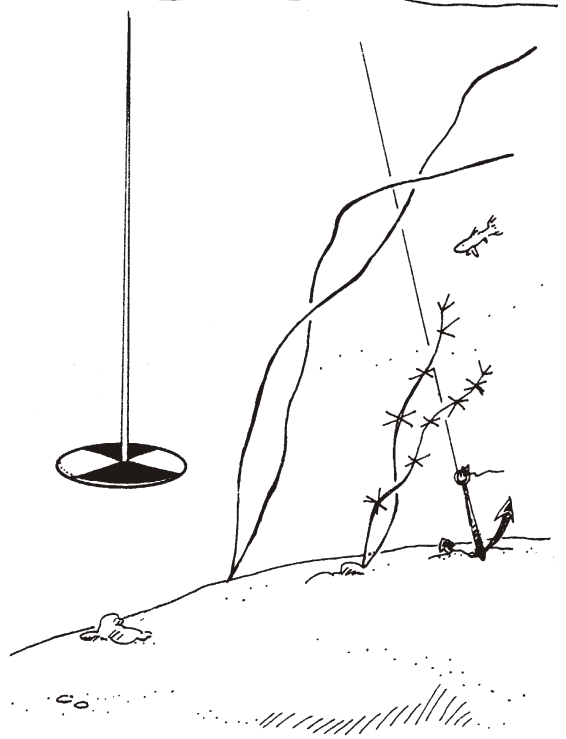

Illinois

**V olunteer
L ake
M onitoring
P rogram**

**Training
Manual**



Illinois Environmental Protection Agency
Division of Water Pollution Control – Surface Water Section
1021 North Grand Ave., East; P.O. Box 19276
Springfield, Illinois 62794-9276
telephone: 217-782-3362; fax: 217-785-1225
www.epa.state.il.us

Third Edition
January 2010

revised February 2014

This page intentionally blank for
double-sided printing.

Questions?

If you have any questions about the monitoring procedures, the equipment you are using, or any other aspect of the Volunteer Lake Monitoring Program (VLMP), please contact your Regional Coordinator or the Statewide Coordinator at Illinois EPA.



Statewide Coordinator: **Greg Ratliff** 217-782-3362
Illinois EPA, DWPC, SWS #15 greg.ratliff@illinois.gov
1021 North Grand Ave. East, P.O. Box 19276
Springfield, IL 62794-9276

Regional Coordinators:

Northeastern
Holly Hudson 312-454-0400
hhudson@cmap.illinois.gov

Chicago Metropolitan Agency for Planning (CMAP)
233 S. Wacker Drive, Suite 800, Chicago, IL 60606

Lake County
Kelly Deem 847-377-8030
kdeem@lakecountyil.gov

Lake County Health Department (LCHD)
500 W. Winchester Road, Unit #102, Libertyville, IL 60048

Southern
Beau Henson 618-997-9351
beauhenson@greateregypt.org

Greater Egypt Regional Planning & Development
Commission (Greater Egypt)
3000 W. DeYoung St., Suite 800B-3, Marion, IL 62959



VLMP Website: <http://www.epa.state.il.us/water/conservation/vlmp>

This Training Manual can be viewed and downloaded as a PDF document from the VLMP website.

Acknowledgements

The first edition of this Training Manual was written in 1997 by Robert Kirschner and Holly Hudson of the Northeastern Illinois Planning Commission (NIPC) and Amy Burns Walkenbach, Gregg Good, and Jeff Mitzelfelt of the Illinois Environmental Protection Agency (IEPA). Revisions for the 2003 second edition were prepared by NIPC's Holly Hudson and IEPA's Sandy Nickel, with input from Amy Burns Walkenbach and Mike Bundren of IEPA as well as VLMP volunteers across the state. The 2010 third addition was updated and redesigned by Holly Hudson of the Chicago Metropolitan Agency for Planning (CMAP) and IEPA's Sandy Nickel, with input from Mike Henebry, Teri Holland, Tara Lambert, and Joe Marencik of IEPA and Rob Clodi of Greater Egypt. Patrice Charlebois and Kristin TePas of the Illinois Natural History Survey and Illinois-Indiana Sea Grant provided review and comment on the aquatic invasive species section.

Photos by Holly Hudson and Sandy Nickel unless otherwise indicated. Cover graphic design by Adam Weiskind. Title page illustration by Lynda Wallis.

Mention of trade names and commercial products does not constitute endorsement of their use.

Table of Contents

page

Questions? (VLMP contact information).....	i
Acknowledgements	ii
Notes	vi
Illinois Volunteer Lake Monitoring Program	1
Overview	1
Table 1. VLMP Tiered Approach	3
Table 2. Volunteer Qualifications for Tier Placement	4
Volunteer Resources	5
Notes	6
Tier 1 – The "Basic" Monitoring Program (Secchi Disk)	7
Getting Ready	7
Conducting the Tier 1 Basic Program.....	8
Aquatic Invasive Species Monitoring	18
What To Do If You Find Aquatic Invasive Species	21
AIS Monitoring and Specimen Preservation Tips	21
Aquatic Animals	21
Mollusks	21
Crustaceans	24
Fish	26
Aquatic Plants	29
Information Resources for Invasive and Native Aquatic Species	31
Harmful Algal Bloom Program	34
Completing the Secchi Monitoring Form	35
When You Return Home (Tier 1 Basic Program).....	39
Clean-Up & Equipment Storage	39
Submitting Monitoring Data.....	39
Tier 2 and Tier 3 – The "Advanced" Programs (Water Chemistry Sampling, Chlorophyll Sampling, & Dissolved Oxygen/Temperature Measurements).....	41
Laboratory Analyses	41
Suspended Solids	41
Phosphorus	41
Nitrogen	42
Alkalinity	42
Chloride	42
Chlorophyll.....	43

Field Measurements	43
Dissolved Oxygen and Temperature	43
When to Sample	45
Where to Sample	45
Supplies and Equipment to Bring on the Boat	46
Sample Bottle Labels	48
A Clean Boat	49
On-Lake Procedures.....	49
Water Chemistry Sample Collection (Tier 2 & Tier 3)	49
Near-bottom Water Chemistry Sample Collection (Tier 3)	52
Chlorophyll Sample Collection (Tier 3 & select Tier 2)	53
Dissolved Oxygen/Temperature Measurements (Tier 3 & select Tier 2) ...	59
When You Return Home (Tier 2 and Tier 3)	64
Sample Bottle Labels.....	64
Temporary Water Sample Storage	64
Fill Out Water Chemistry Lab Form.....	64
Complete the Secchi Monitoring Form	66
Water Chemistry Sampling Equipment Clean-Up & Storage	66
Filter Chlorophyll Sample (Tier 3 & select Tier 2).....	66
Chlorophyll Sample Label & Temporary Sample Storage	75
Fill out Chlorophyll Lab Form.....	76
Complete the Secchi Monitoring Form	78
Chlorophyll Equipment Clean-Up & Storage.....	78
Dissolved Oxygen/Temperature Meter Care & Storage.....	78
Handheld Electronic Depth Sounder Care & Storage	78
Van Dorn Sampler Care & Storage	78
Shipping the Water Sample Bottles	79
Shipping the Chlorophyll Sample Filter(s)	81
Mailing the Dissolved Oxygen/Temperature Profile Forms	83
Notes	84
Equipment Clean-Up, Care, & Storage	85
Tier 1 Monitoring Equipment.....	85
Water Chemistry Sampling Equipment	85
Chlorophyll Equipment.....	86
Dissolved Oxygen/Temperature Meter	87
Handheld Electronic Depth Sounder	89
Chemical Safety Information – Sulfuric Acid Preservative	90
Record Keeping	91

Personal Record of Observations Form	92
Water Chemistry Laboratory Forms & Shipping Labels (<i>enclosed in a pocket</i>).....	93
Chlorophyll Laboratory Forms & Shipping Labels (<i>enclosed in a pocket</i>)	95
HACH HQ Series Meters – LDO Probe Calibration Procedure	97
Dissolved Oxygen/Temperature Monitoring Forms (<i>enclosed in a pocket</i>).....	101

Appendices:

A. Online Database Secchi Form Entry	A1
(including D.O./Temperature Profile Data Upload Instructions)	
B. Van Dorn Sampler Use, Care & Storage	B1
C. Hydrilla Hunt! Initiative	C1
D. Identifying & Reporting Harmful Algal Blooms	D1

Enclosures:

Training DVD (*enclosed in a plastic sleeve*)

A Guide to Illinois Lake Management

Note: includes *Glossary* of lake-related terms

List of *Lake Notes* Fact Sheets (*in front pocket of binder*)

Aquatic Invasive Species WATCH cards (*enclosed in plastic card holders*)

Look Out for New Aquatic Invasive Plants sheet (*enclosed in a plastic pocket*)

Hydrilla Hunt! laminated ID sheet (*in front pocket of binder*)

Your Lake’s Map (*enclosed in a plastic pocket*)

Secchi Monitoring Forms (*in back pocket of binder*)

Color Chart (*in back pocket of binder*)

Postage-Paid Return Envelopes (*in back pocket of binder*)

NOTES

Illinois Volunteer Lake Monitoring Program

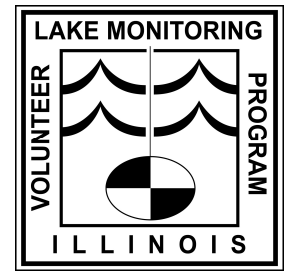

Overview

Thank you for joining the Illinois Volunteer Lake Monitoring Program (VLMP). Since 1981, citizen volunteers, the Illinois EPA, and regional planning commissions have been working together to monitor the quality of Illinois' lakes through the VLMP. This cooperative effort provides information on many more lakes than could be otherwise monitored by state agency staff. The volunteers have learned much about their lakes, and a substantial dataset has been established from information they have collected. The data is used by Illinois EPA in its biennial assessment of the state's waters as required by the Clean Water Act, as well as by lake scientists, planners, consultants, and the volunteers themselves for a wide variety of purposes. A primary goal of the VLMP is to familiarize volunteers with lake processes and the cause and effect relationships that exist between their lake, its watershed, weather, and human activities. Through the VLMP's hands-on educational structure, the data and information gathered can more effectively assist in local lake and watershed management decision-making.

Volunteers first "adopt" a lake of their choosing. In the VLMP's **Tier 1 ("Basic") Program**, volunteers are trained to measure the lake's water clarity with a Secchi disk (*Secchi* rhymes with *Becky*). Volunteers also record water color, aquatic plant growth, and several other factors relating to lake, weather, and watershed conditions at the time of monitoring. Most lakes have three monitoring locations or "sites." **Volunteers are encouraged to take Secchi disk readings at all sites at least twice per month from May through October.** Additionally, volunteers are asked to keep watch for several types of aquatic invasive species, and to report potential sightings. All monitoring equipment, data forms, instructional materials, and other supplies are provided to the volunteers at no charge. Volunteers need only have a boat and anchor to participate.



After actively participating in the Tier 1 (Secchi monitoring) Program for one or more years, volunteers may be offered the opportunity to participate in the **Tier 2 or Tier 3 ("Advanced") Programs** whereby their monitoring efforts are expanded to include the collection of lake water samples. Because volunteer participation in the Tier 2 or Tier 3 programs is dependent on Illinois EPA approval as well as available resources,

involvement in the Tier 2 or Tier 3 Advanced Program is limited and cannot be guaranteed every year. Thus, participation is “rotated” from year to year so that each lake has an opportunity for sample collection.



Water chemistry samples are collected in the Tier 3 program once per month during five months (May–August, October), and in the Tier 2 program once per month during four months (May–August), of the May through October monitoring season. Sample collection is conducted at Site 1 (the representative lake site) in both the Tier 2 and Tier 3 programs. Under the Tier 3 program, sample collection also is conducted at additional monitoring sites.

Volunteers ship their samples to an Illinois EPA or Illinois EPA–certified lab for analysis of several water chemistry parameters. The Tier 2 and Tier 3 water chemistry data provides important information on suspended material in the lake (sediment, algae, etc.), as well as levels of nutrients (phosphorus, nitrogen) that can promote nuisance aquatic plant and algae growth.



In addition to water chemistry samples, Tier 3 and some Tier 2 volunteers also collect and filter water samples for chlorophyll analysis and record dissolved oxygen and temperature measurements. The chlorophyll data is particularly useful in determining the amount of free-floating "planktonic" algae in the lake. Dissolved oxygen and temperature data are useful for determining if the lake is stratified and if there is adequate oxygen in the water to support aquatic life.

Volunteers are provided with all water sampling equipment, bottles, data forms, and other needed supplies, along with pre-paid shipping containers for sending their samples to the lab for analysis.

Illinois EPA uses the water quality data produced under Tiers 2 and 3 for making general water quality assessments. The Tier 3 data is further used by Illinois EPA in their “Integrated Report” (a biennial assessment of the state’s waters as required by the Federal Clean Water Act). This means that Tier 3–monitored lakes may become listed among the state’s “impaired waters” and be subject to potential TMDL (Total Maximum Daily Load) development. Data used for this purpose must be extremely reliable, adequate in amount, and meet minimum data quality requirements.

Note: More information about the water chemistry and chlorophyll analyses as well as dissolved oxygen and temperature measurements can be found beginning on page 41 of this Manual.

The two tables below provide an overview of the VLMP's three tiers and the qualifications for participation in each tier, respectively. If you have any questions about requirements for participation in the Tier 1, Tier 2, or Tier 3 program or how data collected under a tier is used, please contact your Regional or the Statewide VLMP Coordinator.

Table 1. VLMP Tiered Approach – as of 2013

	Tier 1	Tier 2 <i>Tier 1 + Water Quality</i>	Tier 3 <i>Tier 1 + Expanded Water Quality</i>
Lake Type	Public or Private No Size Requirement	Public or Private No Size Requirement	Public or Private > 20 acres except for PWS ¹ lakes (any size)
Purpose	Education + Water Quality Assessments	Expanded Education + Baseline Water Quality Indicators + Water Quality Assessments	Expanded Education + Expanded Water Quality Indicators + Water Quality Assessments + TMDL ² Development
Parameters	Secchi Transparency + Aquatic Plant Coverage, Apparent Color, Lake Water Level, Weather Conditions, Aquatic Invasive Species, Lake & Watershed Management	Tier 1 parameters + Water Chemistry sampling (Total Phosphorus, Total & Volatile Suspended Solids, Nitrate+Nitrite Nitrogen, Ammonia Nitrogen, Total Kjeldahl Nitrogen, Alkalinity, Chloride*) + Chlorophyll sampling* + Dissolved Oxygen (D.O.) / Temperature profiles*	Tier 1 parameters + Water Chemistry sampling (Total Phosphorus, Total & Volatile Suspended Solids, Nitrate+Nitrite Nitrogen, Ammonia Nitrogen, Total Kjeldahl Nitrogen, Alkalinity, Chloride*) + Chlorophyll sampling + Dissolved Oxygen (D.O.) / Temperature profiles
Monitoring Expectations (Frequency)	Twice/month (May – October)	Tier 1 parameters: Twice/month (May – Oct) + Tier 2 Water sampling: 1 time /month, 4 months/year (May – August)	Tier 1 parameters: Twice/month (May – Oct) + Tier 3 Water & Chlorophyll sampling: 1 time /month, 5 months/year (May – August, October) + D.O. / Temperature profiles: Twice/month (May – Oct)
Sites Monitored	All sites	Tier 1 parameters: All sites Water Chemistry & Chlorophyll sampling: Site 1 only D.O. / Temperature profiles: All sites	Tier 1 parameters: All sites Water Chemistry & Chlorophyll sampling: up to 3 sites D.O. / Temperature profiles: All sites
Volunteer Attributes	see Table 2 below	see Table 2 below	see Table 2 below
Training	Personal Training	Centralized and/or Personal Training	Centralized and/or Personal Training (subject to individual audit)

¹ PWS = Public Water Supply
² TMDL = Total Maximum Daily Load
* at select lakes

Table 2. Volunteer Qualifications for Tier Placement

	Tier 1	Tier 2	Tier 3
Previous Experience	<p>No experience needed</p> <p><i>Do need access to a boat, anchor, personal floatation equipment, and Internet (if possible)</i></p>	<p>At least 1 year in Tier 1</p>	<p>At least 1 year in Tier 2</p>
Level of Participation and Proficiency in Previous Year	<p>None</p>	<p>Conducted Tier 1 monitoring at least 9 times during the previous year <i>and</i> at least once during all 6 months of the May-October VLMP season.</p> <p>To remain in Tier 2: As above plus collected water samples correctly and regularly during the previous year.</p>	<p>Conducted Tier 1 monitoring at least 9 times during the previous year <i>and</i> at least once during all 6 months of the May-October VLMP season, and collected water samples correctly and regularly during previous year in Tier 2.</p> <p>To remain in Tier 3: As above plus demonstrated proficiency, accuracy, and reliability in Secchi monitoring procedures, collection and processing of water samples, sample shipping procedures, and equipment care.</p>
Training	<p>Personal training for first time volunteers. Refresher training upon request or at the discretion of VLMP Coordinator.</p>	<p>Personal training for first time Tier 2 volunteers. Refresher training upon request or at the discretion of VLMP Coordinator for volunteers continuing in Tier 2.</p>	<p>Personal training for first time Tier 3 volunteers. Centralized and/or personal refresher training for volunteers continuing in Tier 3. Annual training session is required. Annual audit is required.</p>

The VLMP has a web-based data entry system whereby volunteers can enter their Secchi monitoring data, field observations, and water sampling information directly to Illinois EPA's VLMP database. The VLMP data can be viewed and retrieved by the volunteers as well as the general public.

Volunteer Resources

Included within this Training Manual is a booklet entitled ***A Guide to Illinois Lake Management***. Please take a few moments to read through this booklet. It will help you become more familiar with some basic lake ecology principles, and it provides background on the water quality monitoring you'll be conducting. For additional assistance, there is a listing of resource agencies and publications at the end of the *Guide*.

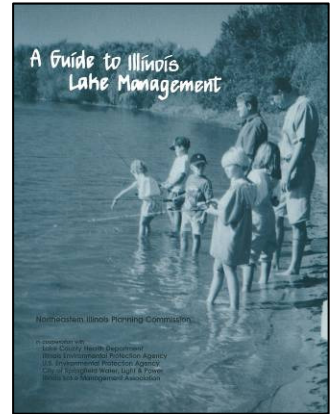

Another useful source of information is a fact sheet series called ***Lake Notes***. Each fact sheet covers a different lake-related topic. A list of *Lake Notes* published to date is provided in the front pocket of this Manual. Copies of each fact sheet are available from your Coordinator. The *Lake Notes* also can be viewed and downloaded as PDF documents from Illinois EPA's website (<http://www.epa.state.il.us/water/conservation/lake-notes/index.html>).

Also included with this Training Manual is an **instructional DVD**. The opening chapter on the DVD provides an introduction and overview of the Illinois VLMP and is suitable for general audiences. The chapter on aquatic invasive species is useful for general audiences as well. The other DVD chapters emulate the monitoring instructions described in this Training Manual, providing a visual "how to" for conducting Secchi disk readings, watching for aquatic invasive species, collecting water and chlorophyll samples, and processing and shipping your samples.



Before the start of each monitoring season...

please take a few minutes to review the Secchi monitoring instructions—and as applicable the water sampling procedures—provided in this Training Manual and on the DVD.

NOTES

TIER 1

The "Basic" Monitoring Program (Secchi Disk)

Getting Ready

Before going out on the lake, make sure that...

- ✓ The weather conditions are favorable.
Sunny, calm days are best. But since this is not always possible—and because regular monitoring is valuable—take readings under the best conditions you can. Of course, NEVER subject yourself to unsafe conditions on the lake.
- ✓ It's the right time of day.
Take your readings between 10 a.m. and 4 p.m.: any earlier or later affects transparency readings because the sun will be too low in the sky.
- ✓ You have your monitoring equipment and supplies:
 - ◆ A boat
 - ◆ Anchor with enough rope to anchor at each site
 - ◆ U.S. Coast Guard approved personal flotation device (PFD) for each person
 - ◆ Secchi disk
 - ◆ Clothespin(s)
 - ◆ Lake map with site location notes
 - ◆ Secchi Monitoring Form
 - ◆ Color chart
 - ◆ Ink pen or sharp pencil (don't use red ink, or felt-tip pens)
 - ◆ Training Manual

- ✓ Other items that can be helpful:
 - ◆ Clipboard
 - ◆ Towel
 - ◆ Electronic depth sounder
 - ◆ Global positioning system (GPS) receiver

Conducting the Tier 1 Basic Program

1. Use your lake map and proceed to Site 1. If it saves you considerable time to visit the monitoring sites in some other order, you may do so but be especially careful that you're filling in each site's information in the correct row on the Secchi Monitoring Form!



It will help to locate the monitoring sites if you place notes on your lake map showing 2 sets of aligning landmarks on shore with "sight lines" drawn to them. The 2 sets of landmarks should be at about a 90 degree angle from each other, which will help get you back in the right location

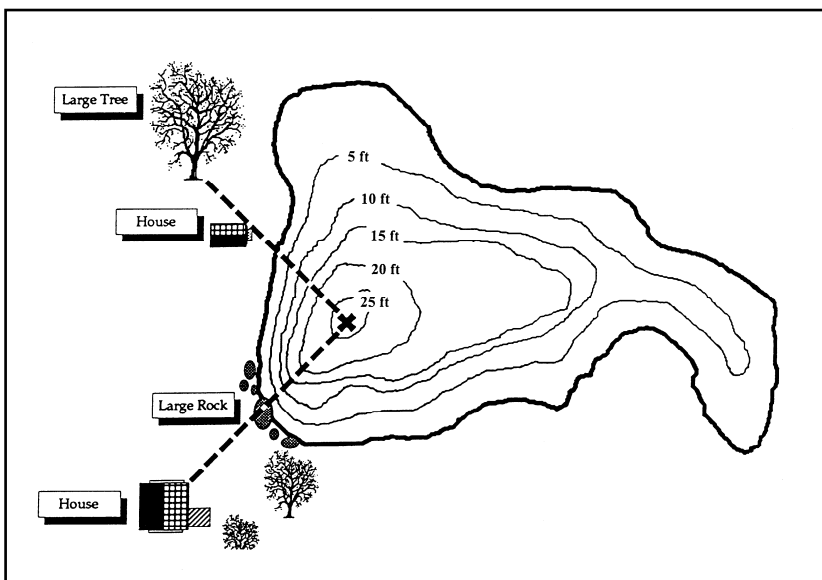

from both a north/south and east/west perspective. Be sure to write down the water depth at each site too. (These notes also will help future volunteers at your lake find the same monitoring site locations).

To establish a sight line, first find a permanent fixture near the shoreline, such as a tree trunk, large rock, flagpole, light post, or other distinguishable object. Next, line up another permanent fixture that's behind the first object, such as a utility pole, water tower, or a particular corner, chimney, or window on a building. Then use the same method to establish a second sight line at an approximate 90 degree angle from the first sight line.

TIPS:

- Once a monitoring site's location is established using sight lines and water depth, if you have a handheld or boat-mounted electronic depth sounder, you can utilize that to help verify you're in the right location each time you monitor.



A handheld electronic depth sounder.

- If you have a GPS (global positioning system) receiver, also write down the latitude and longitude (or “northing” and “easting”) of each site on your lake map. It is also very important to write down the coordinate system and map datum to which the GPS unit was set.

Set the map datum to NAD83 (North American Datum of 1983) or WGS84 (World Geodetic System of 1984). Set the coordinate system to display your position either in Latitude/Longitude in decimal degrees, or in the UTM (Universal Transverse Mercator) coordinate system (which displays position in meters as an “Easting” and a “Northing”).

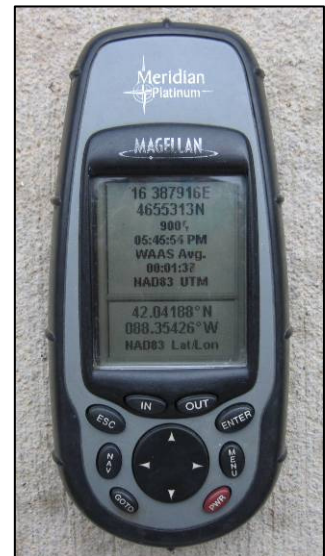

The handheld GPS unit above is displaying position in both UTM coordinates and decimal degrees, using the NAD83 map datum.

2. After reaching the monitoring site, **carefully lower the anchor** over the side of the boat until it reaches the lake bottom.

Let out plenty of anchor line so that your boat drifts away from any sediment that may have been kicked up by the anchor.

NOTE: The force of the anchor hitting the lake bottom will disrupt a certain amount of bottom sediment, causing a sediment "plume." Because Secchi transparency can be affected by this resuspended sediment, it is extremely important to minimize the impact of the anchor upon the lake bottom, especially at monitoring sites with shallow water depths or soft "muck" sediments.

We can't overstate the potential adverse effects that anchor-created sediment plumes can have on your monitoring results! If you see a sediment plume after anchoring, or need to reposition your boat for another reason, very carefully pull up the anchor, move away a short distance, and try anchoring again.



3. Remove sunglasses you may be wearing (though you may leave tinted corrective lenses on). Unwind plenty of the Secchi disk rope (or survey tape) from the dowel rod (or dowel float), and leave the dowel rod/float in the boat. With the Secchi disk in one hand and a clothespin in the other, lean over the shaded side of the boat and—with your eyes directly above the Secchi disk—**slowly** lower the disk into the water until you can no longer see it.



NOTE: By having your eyes directly over the Secchi disk, this positions your head to further shade the water above the disk and reduce glare.

TIP: You also can hold your free arm over the water to help form even more shadow and combat glare.

4. At the point where you lost site of the disk, mark the rope or survey tape at the water level with the clothespin.

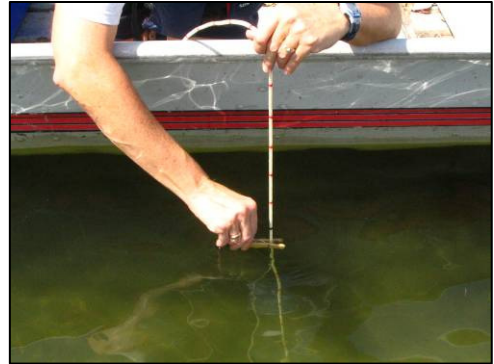

5. Lower the Secchi disk about 1 to 2 more feet into the water (but don't let the disk touch the lake bottom!). Then **slowly** raise the disk back towards the water surface. When the disk reappears, mark the line by pinching the rope/survey tape at the water level with your fingers.



6. Bring the rope/survey tape and Secchi disk back into the boat, being careful not to release your “pinching” fingers.

7. Form a loop between the clothespin and your pinching fingers.



8. Slide the clothespin to the center (the top) of the loop. This marks the average of — or halfway point between — the two transparency readings.

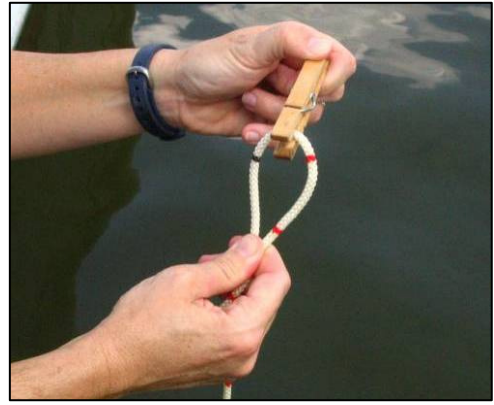

9. Carefully count the number of feet and inches from the disk up to the clothespin. Convert this measurement to the total number of inches. (A feet-to-inches conversion chart is on the back of the monitoring form.) If the clothespin falls between inch marks, choose the closest inch.

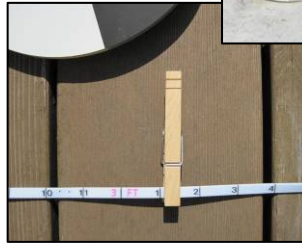

10. Record the Secchi disk transparency measurement (*in inches*) on the Secchi Monitoring Form, along with the time (in 24-hour format) that the measurement was taken.

VOLUNTEER LAKE MONITORING PROGRAM—SECCHI MONITORING							
DIRECTIONS: Anchor boat at each monitoring site. Fill out form as completely and neatly as possible.							
Lake Name: _____		Date: _____		County: _____		Lake Code: _____ Telephone: _____	
Please list the First and Last names of ALL individuals that assisted with this monitoring trip							
Volunteer Name(s): _____							
Site	Time (24 hr (mm))	Secchi Reading (inches)	Secchi Visible on Bottom?	Secchi Hidden by Plants?	Total Depth (nearest 1/2 foot)	Aquatic Plants at Site (circle one)	D.O./Temp. taken?
1	:	Y	N	Y	N	-	0 1 2 3 4 Y N
2	:	Y	N	Y	N	-	0 1 2 3 4 Y N
3	:	Y	N	Y	N	-	0 1 2 3 4 Y N
4	:	Y	N	Y	N	-	0 1 2 3 4 Y N
5	:	Y	N	Y	N	-	0 1 2 3 4 Y N
6	:	Y	N	Y	N	-	0 1 2 3 4 Y N
7	:	Y	N	Y	N	-	0 1 2 3 4 Y N
8	:	Y	N	Y	N	-	0 1 2 3 4 Y N
9	:	Y	N	Y	N	-	0 1 2 3 4 Y N
General Weather Conditions		Cloud Cover (check one)		Waves (check one)			
Amount of Rain in last 48 hrs: _____ inches		<input type="checkbox"/> Sunny		<input type="checkbox"/> Hazy		<input type="checkbox"/> Calm/Ripple	
Wind is out of the: _____		<input type="checkbox"/> Partly Cloudy		<input type="checkbox"/> Overcast		<input type="checkbox"/> Moderate	
<input type="checkbox"/> Small		<input type="checkbox"/> White caps					
Unusual Weather Conditions and Noticeable Lake Changes since last monitoring.		Lake Levels:		Additional Observations (e.g., odor, presence of filamentous algae, recreational usage, unusual conditions in the watershed, etc.).			
		___ "Normal" or Full					
		___ Above "normal" by ___ inches					
		___ Below "normal" by ___ inches					
		Gage Reading: ___ / ___ Units					
Lake/Watershed Management: List all chemical applications and other management techniques since last monitoring (e.g., harvesting, aeration, pumping water into/out of lake, erosion control practices, dredging, fish stocking, etc.). Include dates and descriptions when possible.				Aquatic Exotics: Check all suspected exotics.			
				<input type="checkbox"/> Eurasian Watermilfoil			
				<input type="checkbox"/> Zebra Mussel			
				<input type="checkbox"/> Curlyleaf Pondweed			
				<input type="checkbox"/> Common Carp			
				<input type="checkbox"/> Hydrilla			
				<input type="checkbox"/> Grass Carp			
				<input type="checkbox"/> Water Hyacinth			
				<input type="checkbox"/> Asian Carp			
				<input type="checkbox"/> Rusty Crayfish			
				<input type="checkbox"/> Round Goboy			
				Other: _____			
				Percentage of Lake that contains aquatic plants, both surface and submerged (check one)			
				<input type="checkbox"/> Less than 5%			
				<input type="checkbox"/> 51 to 70%			
				<input type="checkbox"/> 5 to 25%			
				<input type="checkbox"/> Greater than 70%			
				<input type="checkbox"/> 26 to 50%			
Water Quality and Chlorophyll Sampling Programs				List Aquatic Plants Present:			
Indicate bottles collected:	Ammonia, TP, TP	Bottle w/o Acid	Bottle w/o Acid	Chlorophyll	Sample Depth (ft)	Amount Filtered (ml)	
Site 1							
2							
3							
4							
5							
6							
7							
8							
9							
10							
11							
12							
13							
14							
15							
16							
17							
18							
19							
20							
21							
22							
23							
24							
25							
26							
27							
28							
29							
30							
31							
32							
33							
34							
35							
36							
37							
38							
39							
40							
41							
42							
43							
44							
45							
46							
47							
48							
49							
50							
51							
52							
53							
54							
55							
56							
57							
58							
59							
60							
61							
62							
63							
64							
65							
66							
67							
68							
69							
70							
71							
72							
73							
74							
75							
76							
77							
78							
79							
80							
81							
82							
83							
84							
85							
86							
87							
88							
89							
90							
91							
92							
93							
94							
95							
96							
97							
98							
99							
100							
Please Record to the Nearest 1/2 Hour (include travel, preparation, monitoring & paperwork time)		Number of Volunteers		X _____			
Number of hours per volunteer		= _____		Total number of Volunteer Hours = _____			
Datsheet entered online? YES		<input type="checkbox"/>		NO <input type="checkbox"/>			

24-Hour Time Format:

With the 12-hour (a.m./p.m.) clock format, the day is split into two, 12 hour periods: midnight to noon (the a.m. hours), and noon to midnight (the p.m. hours). With the 24-hour clock format, the time is shown as the number of

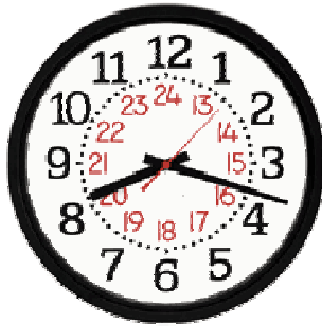

hours and minutes past midnight (**hh:mm**). For example, 9:50 a.m. is 09:50 in 24 hour format. To convert from the a.m./p.m. format for any time after 12:00 p.m. (noon) up until 11:59 p.m., simply add 12 to the hour number that's on the left side of the colon. For example, 1:10 p.m. becomes 13:10 hours, 2:25 p.m. becomes 14:25 hours, and 3:58 p.m. becomes 15:58 hours.

11. Sometimes, the "true" Secchi disk transparency can't be measured because either:
- a) the disk reached the lake bottom and you could still see it, or
 - b) the disk was lost from view because it "disappeared" into dense growth of rooted aquatic plants.

Situation "a"

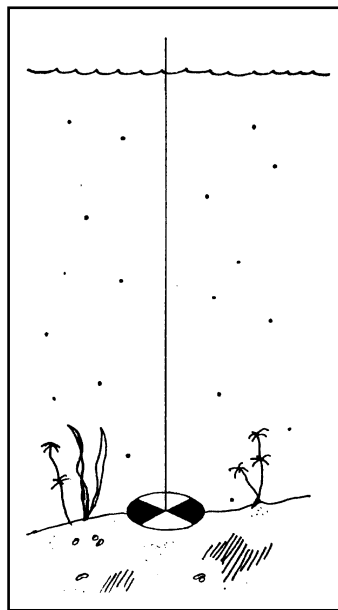

Situation "b"

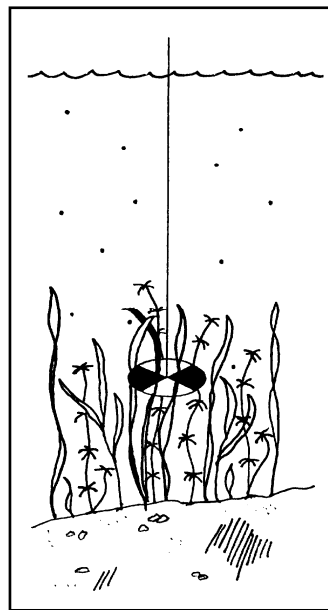

While you can't change how deep your lake is at the monitoring site (situation "a"), sometimes moving a few feet one way or the other will permit you to see the Secchi disk through the aquatic plants (to overcome situation "b"). Always try to obtain Secchi transparency readings that measure the true transparency of the water—not just the transparency to the top of plant beds (though sometimes this situation cannot be avoided at certain monitoring sites).

On your Secchi Monitoring Form, **answer the two "Yes/No" questions** relating to the Secchi disk measurement.

NOTE: Record your Secchi disk transparency reading (i.e., as far down as you could see the disk) even if you answered "Yes" to one of these questions.

12. To determine the water color, lower the Secchi disk (on the shaded side of the boat) to one-half ($\frac{1}{2}$) the Secchi transparency. For example, if your transparency was 66 inches, lower the disk to 33 inches (use the clothespin to mark the rope/survey tape at the proper depth). Hold the Color Chart just **above** the surface of the water near one of the disk's white quadrants. Compare the color of the white quadrant with the various colors on the Color Chart, and record the corresponding number on the Secchi Monitoring Form. If there is no exact match, record the color number that is the closest match.

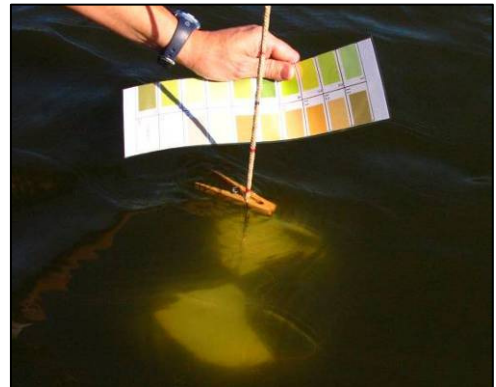

NOTE: If the Secchi transparency was limited by either condition in Step #11 above, you do not have to take a color reading (just place a dash or "n/a" for color on the Secchi Monitoring Form).

IMPORTANT NOTE: Keep the Color Chart out of direct sunlight when not in use (to help prevent fading).

VERY IMPORTANT NOTE: If you are collecting water samples and/or recording dissolved oxygen/temperature measurements at this site as part of the Tier 2 or Tier 3 Advanced Program, you must **STOP** here and proceed to the Tier 2 & Tier 3 Advanced Program instructions (beginning on page 45 of this Manual). When you have completed all the steps in the Tier 2 or Tier 3 Program, you will return to Step #13 below.

13. To measure the site's **total water depth**, lower the Secchi disk all the way to the bottom of the lake. Make sure the rope/survey tape is vertical, then place the clothespin on the rope/survey tape at the water level. Bring the Secchi disk back up into the boat. Determine the site's total depth (the distance between the Secchi disk and the clothespin), and record this depth to the **nearest half-foot** on the Secchi Monitoring Form (e.g., 22.5, 23.0, 23.5 ft.).

VERY IMPORTANT NOTE: Perform this step after you've conducted the Secchi transparency and water color measurements (and water/chlorophyll/dissolved oxygen-temperature sampling for Advanced Program volunteers). Measuring the site's total depth is left until last because when you lift the Secchi disk off the lake bottom, a sediment plume forms and this could greatly affect your measurements (and samples).

14. Pull up your anchor line ... but don't leave yet!



15. Before proceeding to the next site, indicate the relative amount of aquatic plants growing in the immediate vicinity of the monitoring site by circling the appropriate number (0-4) on the Secchi Monitoring Form.

For convenience, the numbers and descriptive names below are found on the back of the Color Chart.

0 = None: no floating-leaved aquatic plants (e.g., lily pads) or submersed (underwater) plants visible or pulled up with the Secchi disk or anchor.

1 = Minimal: only a very few floating-leaved plants or submersed plants visible (or if not visible, a couple/few plant strands might be pulled up with the anchor). Submersed plant growth may be well below the water surface and may or may not be visible as you look into the water.



2 = Slight: a small amount of floating-leaved plants and/or submersed plants visible (or if not visible, a clump of plants might be pulled up with the anchor). Submersed plant growth may be well below the water surface and may or may not be visible as you look into the water.



3 = Moderate: extensive but not complete coverage by floating-leaved and/or submersed plants. Submersed plants would be visible, growing close to the water surface. Boaters and/or swimmers could probably still use the area.



4 = Substantial: complete coverage of the water surface by floating-leaved plants and/or submersed plants that have grown to the water surface. Boaters and/or swimmers would have a difficult time using this area.



16. Proceed to the next monitoring site and complete each of the preceding steps (Steps #1 - #15).

17. If you conduct a search for **aquatic invasive species** (AIS), make a note of this in the "Lake/Watershed Management" section of your Secchi Monitoring Form. More details about AIS monitoring are provided on the following pages.

Indicate on your Secchi Monitoring Form that you conducted an AIS search; what areas of the lake you checked; what objects you inspected, if applicable, in those areas (e.g., multi-plate or concrete block sampler, dock posts, buoys, riprap, etc.); and whether or not you found any AIS at each of those locations. (It is just as important to keep written records even if no AIS were found.) Use additional sheets as necessary for recording notes.

Aquatic Invasive Species Monitoring

Aquatic invasive species are freshwater organisms that spread or are introduced outside their native ranges and cause negative environmental and/or economic impacts. You also may hear aquatic invasive species (AIS) called aquatic “exotic,” “nuisance,” or “nonindigenous” species. Unfortunately, more than 85 AIS have been introduced into Illinois. The zebra mussel, Eurasian watermilfoil, and silver carp are all examples of invaders that have impacted our state.

Aquatic invaders such as these have been introduced and spread through a variety of activities including those associated with recreational water users, backyard water gardeners, aquarium hobbyists, natural resource professionals, the baitfish industry, and commercial shipping. The Illinois VLMP is partnering with Illinois–Indiana Sea Grant, the Illinois Natural History Survey, and the Midwest Invasive Plant Network to monitor for and help prevent the spread of aquatic invasive species to our state’s lakes.



Eurasian watermilfoil (photo by Chris Evans, River to River CWMA, Bugwood.org)

Your efforts will help reduce the negative environmental and financial impact AIS have on Illinois. As lake stewards, you are often the first line of defense against AIS by keeping watch for new aquatic invaders in your lake, preventing the spread of AIS that may already be established, and educating others about AIS.

All VLMP volunteers are requested to participate in the AIS monitoring effort. Provided in this Training Manual is a set of AIS “WATCH” cards that provide a photo, sketch, description, and identification tips for several invasive fish, mollusk, crustacean, and aquatic plant species. Also provided is a “**New Aquatic Invasive Plants**” identification sheet with photos and descriptions of several aquatic invasive plants which have been documented in the Midwest, and a “**Hydrilla Hunt!**” identification sheet. Please review each WATCH card, the New Aquatic Invasive Plants sheet, and the Hydrilla Hunt! sheet – and keep an eye out for these and other aquatic invaders. Your help detecting and reporting new infestations is vital for preventing their spread.

Because you may not be the first person to notice or suspect an aquatic invader in your lake, nor can one person be on watch for potential AIS transfers 24 hours a day, an informed network of lake community residents and recreational users is key to preventing introductions into your lake or spreading AIS to other waterbodies. The Illinois–Indiana Sea Grant College Program and the “Stop Aquatic Hitchhikers” campaign provide excellent information, ideas, resources, and products for helping you and your community promote awareness and encourage actions to help prevent the spread of AIS. The following websites can help get you started:

- http://iiseagrant.org/topic_ais.html
- http://iiseagrant.org/catalog/products_ais.html
- <http://www.protectyourwaters.net/>

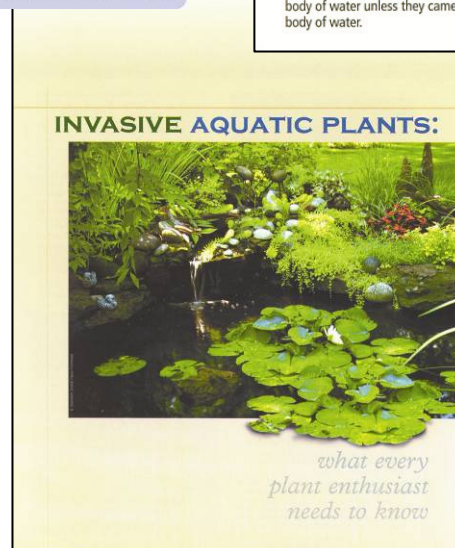
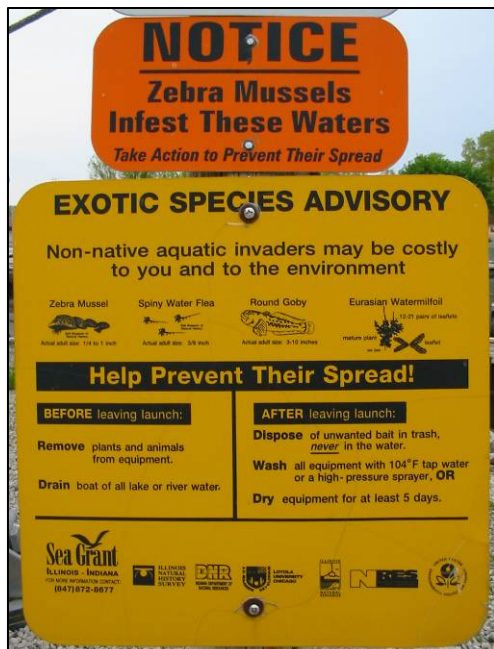

(Brochure and sticker images courtesy of Illinois-Indiana Sea Grant)

HELP SAFEGUARD ILLINOIS' LAKES BY KEEPING AN EYE OUT FOR THESE AND OTHER AQUATIC INVASIVE SPECIES

Refer to the AIS WATCH cards, New Aquatic Invasive Plants identification sheet, and Hydrilla Hunt! identification sheet (along with Appendix C: Hydrilla Hunt! Initiative) provided with this VLMP Manual, as well as the resources listed on pages 31–33.

Mollusks

- Zebra mussel
- Quagga mussel
- New Zealand mudsnail
- Asian clam

Crustaceans

- Rusty crayfish
- Spiny waterflea
- Fishhook waterflea
- Bloody red shrimp

Fish

- Round goby
- Bighead & Silver carp
(Asian carps)
- Ruffe
- White perch



A flowering rush plant in bloom.

Aquatic Plants

Submersed (underwater) plants:

- Eurasian watermilfoil
- Curlyleaf pondweed
- Brazilian elodea
(Brazilian waterweed)
- Hydrilla
- Indian swampweed
- Brittle water nymph
(Brittle naiad)

Free-floating plants:

- European frogbit
- Water hyacinth
- Water lettuce

Rooted, floating-leaved plants:

- Pond water-starwort
- Swamp stone crop
- European watercress
- Yellow floating heart
- Water chestnut

Emergent (above water) plants:

- Purple loosestrife
- Flowering rush
- Reed manna grass
- Parrot feather

WHAT TO DO IF YOU FIND AQUATIC INVASIVE SPECIES

If you find—or suspect you have found—any aquatic invasive species, make note of exactly where it was found, take photos if possible, and collect and preserve some specimens if possible, following the tips provided for the various species below. Then contact your Regional VLMP Coordinator or the Statewide VLMP Coordinator (contact information is on page –i– of this Manual) for further instructions about where to send your specimens for identification.

AIS MONITORING AND SPECIMEN PRESERVATION TIPS

AQUATIC ANIMALS

- **MOLLUSKS**

Zebra and Quagga Mussels (*Dreissena polymorpha* and *D. bugensis*): You can monitor for adult zebra and quagga mussels by (a) immersing hard substrates (e.g., concrete blocks) in areas around the lake and inspecting them regularly throughout the VLMP monitoring season; and (b) checking submersed portions of recreational or navigational equipment (e.g., boats, docks, buoys, swimming area ropes) during the monitoring season as well as when they are removed from the lake for repair or winter storage. Also, if lake water levels go down during the summer or fall, a walk along the shoreline might reveal these mussels attached to exposed rocks, riprap, seawalls, pier posts, native mussels, or any other hard surface, although quaggas also do well in silty or sandy areas. Quaggas also tend to prefer deeper water where there is less wave action.



Zebra mussels exposed on a pier post during low lake levels.

Inspection for zebra and quagga mussels should be done at least once per month, to coincide with a Secchi disk monitoring date. It is best to monitor several areas of the lake because these mussels can be localized for a long

period before they spread to other areas. One key area to monitor is near a likely point of mussel introduction (such as a boat launch or marina, resorts and campgrounds, and in some cases, near an inflowing tributary). Your VLMP Coordinator can work with you to determine the best location(s) for zebra and quagga mussel monitoring.

To inspect a submerged substrate for the presence of zebra and quagga mussels, lift it from the water and visually scan its surfaces. Use a Zebra Mussel WATCH card and the photo below to help with identification. A magnifying glass may also be useful. If you don't see any zebra or quagga mussels, carefully run your hand over all the surfaces to feel for small, crusty bumps. Zebra and quagga mussels do not like direct sunlight and are often found on the underside of rocks and structures or in cracks and crevices. Adult zebra and quagga mussels may also be found attached to aquatic plants. (This is one of the ways zebra and quagga mussels can get transported to other lakes—attached to aquatic plants which are “hitching a ride” on boats and trailers.)

While both zebra and quagga mussels have dark stripes on usually tan- or cream-colored shells, the quagga mussel shell has a more rounded shape and is more pale toward the area where its two shells attach. The bottom side of the quagga mussel where the two shells attach is convex, which

makes the quagga topple over when you try to stand it up on a flat surface. This is unlike the zebra mussel, which has a flat bottom where the two shells attach and thus remains upright when it's placed on a flat surface. Size is not an absolute identification trait since there is an overlap in size ranges between the two species. While both zebra and quagga mussels attach to hard surfaces (such as boat hulls, intake pipes, pier posts, rocks), quaggas also inhabit silty or sandy lake bottoms where you typically won't find zebra mussel colonies. Quaggas also tend to grow in single layers and in a more

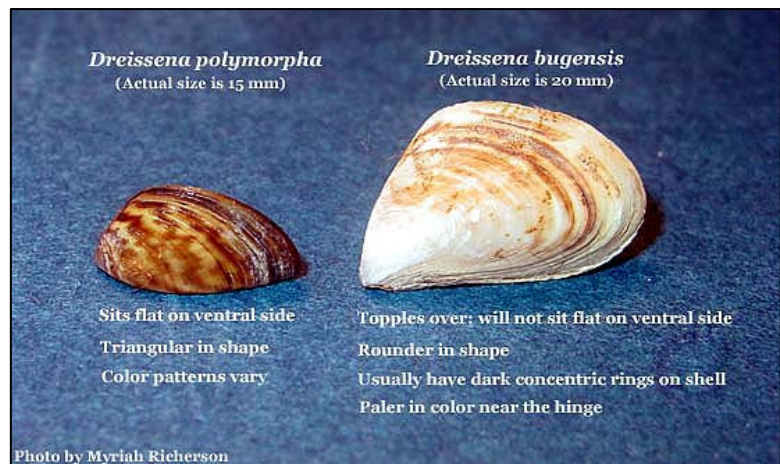

A zebra mussel and a quagga mussel side by side (from USGS Nonindigenous Aquatic Species website; photo by Myriah Richerson).

patchy pattern than zebra mussels, and they can tolerate colder water temperatures, even reproducing in water as cold as 4–9°C (39–48°F). Zebra mussels attach to each other and tend to form clumps of mussels, and need water temperatures greater than 10°C (50°F) to reproduce.

In Illinois, zebra and quagga mussels have become established in Lake Michigan. While so far quagga mussels have not been discovered beyond Lake Michigan in Illinois, zebra mussels have infested several river systems in the state (including the Calumet, Chicago, Des Plaines, Fox, Kankakee, Illinois, Mazon, Mississippi, Ohio, Rock, Wabash, and possibly DuPage Rivers) and numerous inland lakes (primarily in northeastern Illinois within Cook, DuPage, Grundy, Kankakee, Lake, and McHenry Counties but also in southwestern Illinois in Calhoun County).

For species identification, preserve several mussels in a leak-proof (preferably plastic) jar/bottle with rubbing (isopropyl) alcohol. Then contact your Regional or the Statewide VLMP Coordinator for further instructions about where to send your specimens.

In lakes with an already-established population of zebra mussels, a substrate sampler can be used to quantify mussel densities. These samplers are available from your Coordinator upon request.

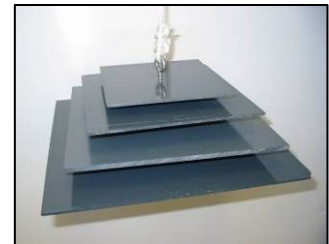

Asian Clam (*Corbicula fluminea*, *C. manilensis*): While this small clam—usually less than 2.5 cm (1 inch) but up to 6.5 cm (2.5 inches) long—will inhabit rocky and gravelly areas (as well as water intake pipes), it tends to prefer sandy and muddy-bottomed lake areas. They may be at the sediment surface or slightly buried. Asian clams can survive in cold water (0–2°C) (32–



Close-up of an Asian clam (from USGS Nonindigenous Aquatic Species website; photo by Noel Burkhead).

36°F), but they need warmer temperatures of 16°C (61°F) or higher to reproduce — which they can do rapidly, leading to densities that can rival those of zebra mussels.

In Illinois, these clams have been documented in several river systems in the state (including the Des Plaines, Kankakee, Illinois, Iroquois, Mississippi, Ohio, Sangamon, Spoon, and

Wabash Rivers) and several lakes (including Crab Orchard, Decatur, Mattoon, McMaster, Sangchris, and Springfield).

Native as well as nonindigenous fingernail or pea clams (Sphaeriids) may resemble the Asian clam. **For identification**, preserve several of the clams in a leak-proof (preferably plastic) jar/bottle with rubbing (isopropyl) alcohol. Then contact your Regional or the Statewide VLMP Coordinator for further instructions.

New Zealand Mudsnail (*Potamopyrgus antipodarum*): This tiny snail—usually 5 mm (3/16 inch) but up to 8 mm (5/16 inch) in length—has invaded many waters across the western United States and has been found in the Midwest in Lakes Ontario, Superior, Erie, and Michigan. Because females can reproduce asexually, new populations of this species can become established quickly and grow rapidly following the introduction of just one snail. Look for these snails on docks, rocks, and other hard surfaces along the shorelines.



Numerous New Zealand mudsnails next to a dime (photo from USGS Florida Integrated Science Center website).

Several native snail species may resemble the New Zealand mudsnail. **For identification**, preserve several snail specimens in a leak-proof (preferably plastic) jar/bottle with rubbing (isopropyl) alcohol. Then contact your Regional or the Statewide VLMP Coordinator for further instructions.

• CRUSTACEANS

Rusty Crayfish (*Orconectes rusticus*): Though native to the Ohio River drainage basin, these crayfish are invasive throughout the remainder of the Midwest. Their aggressive nature displaces native crayfish, from which they usually can be distinguished by a pair of dark, rust-colored spots on the sides of their carapace (shell) just above the tail. Rusty crayfish might be seen while wading in shallow water or in anglers' bait buckets (though it is

illegal to sell or use live rusty crayfish as bait in Illinois). They prefer lakes with gravelly and clay/silt bottoms, in areas with rocks and logs. Rusty crayfish don't seem to thrive as well in lakes with muck bottoms.



A rusty crayfish (from Minnesota Sea Grant website; photo by Jeff Gunderson).

You can try to capture crayfish by hand, using a dip net, or setting out baited minnow traps. To preserve crayfish specimens for identification, freeze them separately in sealed plastic bags. You may want to take some photos of your specimens too. Then contact your Regional or the Statewide VLMP Coordinator for further instructions.

If you notice or suspect that rusty crayfish are being sold in Illinois, contact the Illinois Department of Natural Resources - Office of Law Enforcement at their TIP Hotline: 1-877-2DNRLAW (1-877-236-7529).

Spiny and Fishhook Waterfleas (*Bythotrephes longimanus* and *Cercopagis pengoi*): Anglers frequently discover new infestations of these tiny crustaceans because they foul fishing gear by sticking in jelly-like masses to fishing lines and downrigger cables. Both species are established in all the Great Lakes including Lake Michigan. They can be transported to inland lakes by fishing gear contaminated with egg-laden females, as well as in bait buckets and live wells filled with waterflea-infested water.

For species identification, take some photos of the waterflea mass, and preserve a sample of the specimens in a leak-proof (preferably plastic) jar/bottle with rubbing (isopropyl) alcohol. Then contact your Regional or the Statewide VLMP Coordinator for further instructions on where to send them for identification.



A mass of spiny waterfleas on some fishing line (photo from Minnesota Sea Grant website).

Bloody Red Shrimp (*Hemimysis amonala*): The bloody red shrimp was first found in Lakes Michigan and Ontario in 2006, and has also been reported in Lake Erie. This small shrimp (6.5–11 mm, or 1/4 to 7/16 inches, in length) avoids direct sunlight, so during daylight hours, they may be seen swarming in the shadows of piers, boats, or breakwalls. They're also usually found around hard structures or rocky bottoms rather than soft sediments. Their coloring ranges from bright red to orangish-red to ivory yellow to transparent. Native opossum shrimp look very similar, but they do not swarm together like bloody red shrimp.



A bloody red shrimp as seen under a microscope (photo from NOAA National Center for Research on Aquatic Invasive Species website).

If you think you see a swarm of these shrimp, take a picture of the swarm and try to scoop up some of the shrimp with a dip net or bucket. Preserve some specimens in a leak-proof (preferably plastic) jar/bottle with rubbing (isopropyl) alcohol. Then contact your Regional or the Statewide VLMP Coordinator for further instructions.

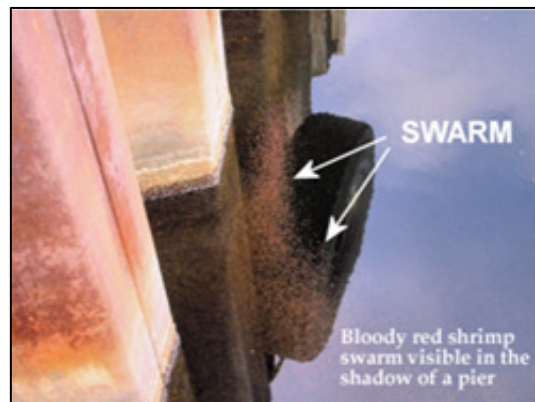

A swarm of bloody red shrimp in the shadow of a pier (photo from NOAA National Center for Research on Aquatic Invasive Species website).

- **FISH**

Round Goby (*Neogobius [=Apollonia] melanostoma*): Anglers are often the first to discover new round goby populations because these aggressive fish are commonly caught by hook and line. Round gobies being used as bait is a likely pathway for introduction into inland lakes by unwary anglers because round gobies may be scooped up when seining for minnows. Regardless, it is illegal to possess round gobies in Illinois.

To date, round gobies have invaded Lake Michigan and are present in the Des Plaines River, Chicago Sanitary and Ship Canal, Calumet Sag Channel, the Upper Illinois River as far south as Peoria lock and dam, and in Wolf Lake on the Illinois/Indiana border.

Round gobies look similar to the native sculpin, but the round goby has a single, scallop-shaped pelvic (belly) fin, while the sculpin has two pelvic fins.

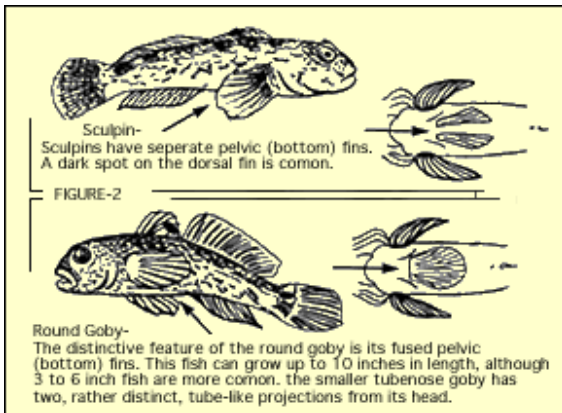

Sculpin and round goby identification characteristics (from the Protect Your Waters website; illustration by Jude and Marsden, 1995).

To preserve a suspected round goby specimen for positive identification, freeze it in a sealed plastic bag. You may want to take some photos of your specimens too. Then contact your Regional or the Statewide VLMP Coordinator for further instructions.

If you notice or suspect that round gobies are being sold in Illinois, contact the Illinois Department of Natural

Resources – Office of Law Enforcement at their TIP Hotline: 1-877-2DNRLAW (1-877-236-7529).

Bighead and Silver Carp (*Hypophthalmichthys nobilis* and *H. molitrix*): These Asian carps, which can reach 50 pounds, are present in the Mississippi, Ohio, and Illinois Rivers and several of their tributaries. Because their juveniles look similar to native baitfish minnows, wild bait harvest and release of live bait can contribute to the spread of these invasive fish to new waters.

Silver carp are easily startled and will leap up to 10 feet out of the water when disturbed by boat motors, and thus can injure people working or recreating on the water. (Video footage of leaping silver carp can be seen in the AIS section of the VLMP instructional DVD.)

If you see “flying” fish or believe you have caught one of these Asian carps, take some photos and freeze any specimens in a sealed plastic bag. Then contact your Regional or the Statewide VLMP Coordinator for further instructions.

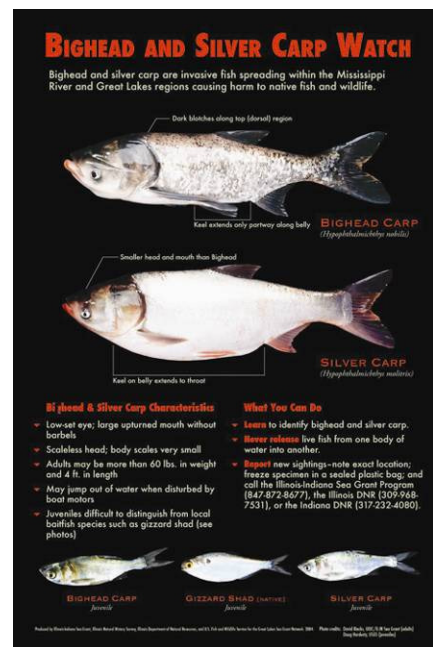

Bighead and Silver Carp Watch poster (image courtesy of Illinois-Indiana Sea Grant).

Ruffe (*Gymnocephalus cernuus*): The Eurasian ruffe (rhymes with tough) has been found in Lakes Superior and Huron, the northern region of Lake Michigan, and some tributaries to those lakes. The potential for its spread into other Great Lakes, as well as to inland waterbodies through the use of live bait, is of great concern. Anglers might be the first to discover ruffe because these fish are commonly caught by hook and line.

Yellow perch (*Perca flavescens*) may resemble the ruffe, but yellow perch have two separate dorsal (top) fins and dark vertical bars on the body. For positive identification, freeze suspected ruffe specimens in a sealed plastic bag. You also may want to take some photos of your specimens. Then contact your Regional or the Statewide VLMP Coordinator for further instructions.



Two adult ruffe next to a ruler (photo from USGS Nonindigenous Aquatic Species website).

White Perch (*Morone americana*): While native to the Atlantic coastline of North America, white perch are invasive in the Midwest. They have become established in all five Great Lakes. In Illinois, white perch have also been found in the Illinois and Ohio Rivers. Unauthorized stocking has been a source of introduction to inland waterbodies in other states. White perch are actually a species of bass, so they can interbreed with our native white bass (*Morone chrysops*), resulting in hybrids with blended characteristics.



An adult white perch (photo from Minnesota Sea Grant website).

Like the ruffe, anglers might be the first to discover white perch. For positive identification, take some photos and freeze specimens in a sealed plastic bag. Then contact your Regional or the Statewide VLMP Coordinator for further instructions.

AQUATIC PLANTS

There are several aquatic invasive plant species for which to keep watch. Some species—such as Eurasian watermilfoil, curlyleaf pondweed, and purple loosestrife—can be found throughout much of Illinois, while to date others have only been found in isolated locations within Illinois or in neighboring states. These invaders often look similar to some of our native aquatic plants, so careful inspection is necessary for positive identification. There are numerous aquatic plant identification guides available to help you identify our native aquatic plants from the aquatic invasive plants. A few are listed among the resources on pages 31–32.



Curlyleaf pondweed (photo courtesy of Frank Koshere, Wisconsin DNR).

Search the lake for aquatic invasive plants at least once per month, to coincide with a Secchi disk monitoring date. Nearshore areas by boat launches, fishing piers, or where other waterbodies flow into the lake are often the first places you'd find new infestations. To aid your search, polarized sunglasses or a view scope can help combat glare or rippled waves on the water surface. To collect aquatic plants that are out of reach in deeper water, you can make your own aquatic plant rake tied to a rope (instructions can be found here: <http://www.umass.edu/tei/mwwp/weedmap.html>).



If you find or suspect you have found any of the aquatic invasive plants described on the WATCH cards or the New Aquatic Invasive Plants sheet, take a photo of the plants at their location and collect some specimens.

- Try to collect the entire plant, including seed heads (fruits), flowers, stem, leaves, and roots/rhizomes. Rinse or shake off any excess soil or sediment while at the collection site.
- Using a permanent marker, label a recloseable plastic bag(s) (usually 1– or 2–gallon size bags work well) with the date, lake name, county, your name, and any other plant collection notes you'd like to add.

- Wrap the specimens in some newspaper and place them in the recloseable plastic bag(s) immediately after collecting them so they don't dry out. The water on the plants will usually be enough to keep them moist, though you can add a few drops of lake or tap water to the bag if you think it's needed.
 - For larger plants (such as tall emergent plants), place the underwater or underground portion of the plant (roots, rhizomes) in the bag and tighten around the stem to keep the moisture in. If fruits/seeds are falling off, tighten another plastic bag around that part of the plant.
- Close the bag(s) with air inside which helps cushion and protect the plants.
- Keep the plants refrigerated until you are ready to send them in for positive identification, which should be done within a few days of collection.
- Contact your Regional or the Statewide VLMP Coordinator for further instructions about where to send your plants for identification.

INFORMATION RESOURCES

FOR INVASIVE AND NATIVE AQUATIC SPECIES

MONITORING, IDENTIFICATION, AND OUTREACH

AIS Experts

- Illinois–Indiana Sea Grant – Aquatic Invasive Species program staff:
Patrice Charlebois (ph: 847–242–6441; e–mail: charlebo@illinois.edu)
Sarah Zack (ph: 847–242–6440; e–mail: szack@illinois.edu)
Danielle Hilbrich (ph: 847–242–6442; e–mail: hilbrich@illinois.edu)
Greg Hitzroth (ph: 217–300–0182; e–mail: hitzroth@illinois.edu)

Websites

- Illinois–Indiana Sea Grant
http://iiseagrant.org/topic_ais.html
AIS news, information about IISG’s education and research programs, and links to other AIS websites.

http://iiseagrant.org/catalog/products_ais.html
Displays the numerous AIS information and education materials available to order through Illinois–Indiana Sea Grant. Products include brochures, fact sheets, species WATCH cards, advisory signs, fact sheets, stickers, magnets, posters, and more.
- Protect Your Waters: Stop Aquatic Hitchhikers!
<http://www.protectyourwaters.net/>
Wealth of information and downloadable resources for educating yourself and others about AIS and how to help stop their spread.
- Nonindigenous Aquatic Species – U.S. Geological Survey
<http://nas.er.usgs.gov/>
Information, color photos, distribution maps, and databases for numerous aquatic invasive species. Site maintained by the U.S. Geological Survey, Florida Integrated Science Center.
- The Center for Aquatic and Invasive Plants – University of Florida
<http://plants.ifas.ufl.edu/>
Information and color photos for more than 500 aquatic plants, as well as short identification videos for many species. The site also contains 175 botanical drawings and numerous other resources.

- An Image–Based Key to the Zooplankton of the Northeast USA

<http://cfb.unh.edu/CFBKey/html/index.html>

Color photos are the basis of this identification key for more than 150 zooplankton species, including the invasive spiny and *Daphnia lumholtzi* waterfleas. Some species with short video clips. A CD is also available. Created and maintained by the University of New Hampshire Center for Freshwater Biology.

Manuals and Guidebooks

- Aquatic Invasive Species Monitoring Procedures – Wisconsin Citizen Lake Monitoring Network

<http://www.uwsp.edu/cnr/uwexplakes/CLMN/AIS-Manual/AISmanualFULL-7-13-09forWEB.pdf>

By Herman. 2009. 272 pages. A detailed training manual prepared for Wisconsin’s Citizen Lake Monitoring Network. Sections on Eurasian watermilfoil, curlyleaf pondweed, purple loosestrife, hydrilla, rusty crayfish, zebra and quagga mussels, mystery snails, waterfleas, freshwater jellyfish (non–native but not invasive), and New Zealand mudsnail.

- Field Guide to Aquatic Invasive Species: Identification, collection, and reporting of aquatic invasive species in Ontario waters

http://www.invadingspecies.com/GetFile.cfm?ID=21570_FieldGuideLR1.pdf

By Lui, Butler, Allen, da Silva, Brownson. 2008. An extensive guide covering more than 50 species of algae, plants, invertebrates, and fishes. Produced by the Ontario Ministry of Natural Resources.

- Through the Looking Glass: A Field Guide to Aquatic Plants

<http://www.uwsp.edu/cnr/uwexplakes/publications/fieldguide/TLGDescription.asp>

By Borman, Korth, and Temte. 1997. 248 pages. Produced by the Wisconsin Lakes Partnership and the University of Wisconsin Extension Service. Covers about 90 plants using drawings for identification. Each species includes a description, similar species, origin and range, habitat, when it grows, and value in the aquatic community. Plants are arranged in sections: emergent, free–floating, floating–leaf, and submersed. Native, exotic, and rare plants are noted.

- Water Plants for Missouri Ponds

<http://www.mdcnatureshop.com/water-plants-for-missouri-pond-pr-267.html>

By Whitley, Bassett, Dillard, and Haefner. 1990. 151 pages. Produced by the Missouri Department of Conservation. Covers 75 species using fine line drawings and photographs for identification. Each species has a description, where and when it grows, values and uses, culture, names and nomenclature, and suitability for ponds.

- **Field Guide to Freshwater Mussels of the Midwest**
<http://www.inhs.uiuc.edu/cbd/collections/mollusk/fieldguide.html>
 By Cummings and Mayer. 1992. 208 pages. Produced by the Illinois Natural History Survey. Covers about 75 native mussel species with color photos and descriptions of key identification characteristics, habitat, and range maps.
- **A Field Guide to the Freshwater Mussels of Chicago Wilderness**
<http://fm2.fieldmuseum.org/plantguides/guideimages.asp?ID=360>
 By Klocek, Bland, and Barghusen. 2008. 92 pages. Produced by Chicago Wilderness. Covers 38 native and 3 invasive mussel species known to currently exist within the Chicago Wilderness region (NE Illinois, SE Wisconsin, NW Indiana). Several color photos provided for each species, plus descriptions of distinguishing identification features, habitat, and regional and national range maps.
- **The Fishes of Illinois**
<http://www.press.uillinois.edu/books/catalog/64eyz4az9780252070846.html>
 By Smith. 2002. 352 pages. Produced by the Illinois Natural History Survey. Covers 99 fish species using line drawings and color plates, descriptions of identification characteristics, and Illinois distribution maps.
- **A Field Guide to Fish Invaders of the Great Lakes Region**
<http://iiseagrant.org/catalog/ais/flgdgl.htm>
http://www.seagrant.umn.edu/downloads/fish_guide_final.pdf
 20 pages. Produced by Sea Grant–Great Lakes Network. Covers 38 invasive and common, native look-a-like fishes using color illustrations and descriptions of key identification characteristics.

Harmful Algal Bloom Program

All VLMP volunteers are requested to participate in Illinois EPA's Harmful Algal Bloom (HAB) Program, initiated in 2013. Please see Appendix D: Identifying & Reporting Harmful Algal Blooms in Illinois, for more information about HABs and how to report them.

Completing the Secchi Monitoring Form

Complete the Secchi Monitoring Form by answering the following questions:

At the Top of the Form: Write down the **Lake Name**, **County**, and the lake's assigned 3- or 4-letter **Lake Code** (below is a table where you can record the lake code for the lake(s) you monitor), along with the monitoring **Date**, your **Name**, and your **Telephone** number. Be sure to include the names of ALL volunteers who assisted with this monitoring trip. The volunteer who took the Secchi disk readings should be listed first.

Lake Name	County	Lake Code

Amount of Rain: Record how much rain has fallen at your lake in the past 48 hours. If you live on or near the lake and have a rain gage in your yard, great! Other sources for daily rainfall information include NOAA weather radio and weather websites. Otherwise, do your best to estimate. If you're completely unsure, just leave this section blank or write in a “?” mark.

Wind Direction, Cloud Cover, and Waves: Indicate the wind direction (direction from which the wind was blowing), cloud cover, and wave strength while you were out monitoring. If any of these changed while you were monitoring, note which conditions changed and what the changes were.

Unusual Weather Conditions and Noticeable Lake Changes: Provide an overall assessment of general weather conditions since the last time you monitored, particularly noting any unusual conditions (e.g., hot or cold spells, severe storms, rainfall totals, high winds, drought conditions, etc.). Also indicate any noticeable changes in the lake's appearance or condition since the previous monitoring date (e.g., greener, browner, or clearer water; more/less aquatic plant growth or floating algae in shoreline areas, etc.).

Lake Level: Establish a benchmark on a fixed object sticking out of the water, preferably an object that doesn't move from year to year and is unaffected/unmoved by winter ice. Concrete or steel structures for lake dams, seawalls, piers, or stormwater inlet or outlet pipes usually are reasonably stable.

"Normal" lake water elevation can be best defined as:

- a) when the lake's water level is even with the crest (top edge) of the dam's spillway or outlet control structure (if the lake has a dam or some sort of outlet structure), or
- b) if the lake does not have an outlet structure of some sort, the "average" elevation of the lake in early to mid-summer.

On each monitoring date, indicate on the Secchi Monitoring Form whether the lake level is normal, above normal, or below normal. Record the inches above or below normal (can measure using a ruler or the Secchi disk rope/survey tape).



At this lake outfall structure, the water depth over the top, outer edge of the spillway was about 1/2 inch (measured with a ruler). The volunteer monitor thus recorded on the Secchi Monitoring Form that the Lake Level was "Above normal by 1/2 inch."



At this outlet structure, there was no flow out of the lake. The water level was measured with a ruler to be about 1 1/4 inch below the top edge of the spillway. The volunteer monitor thus recorded that the Lake Level was "Below normal by 1 1/4 inch."

If there's a staff gage installed at your lake, also record the gage reading and units on your Secchi Monitoring Form. A staff gage is a big ruler vertically mounted, painted, or etched on a permanent fixture such as a pier post, bridge support, or dam abutment; or mounted on a semi-permanent fixture such as a steel sign post that has been pounded several feet into the lake

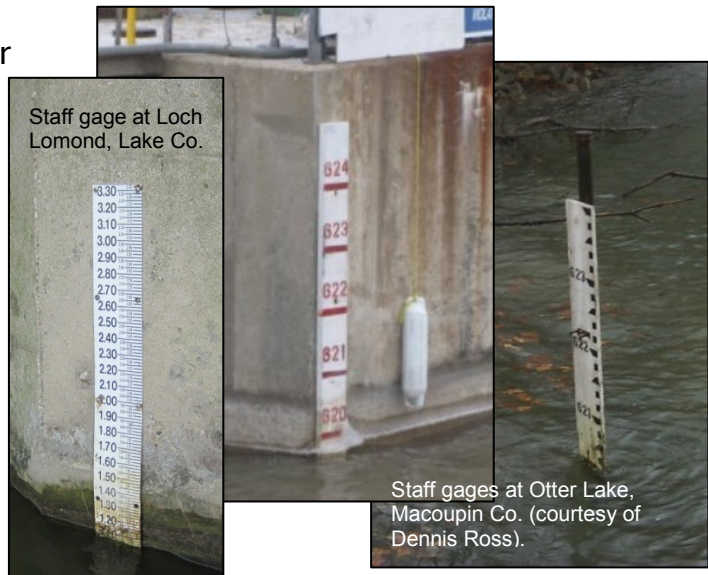

Staff gage at Loch Lomond, Lake Co.

Staff gages at Otter Lake, Macoupin Co. (courtesy of Dennis Ross).

bottom. The height of the water in relation to the graduations on the gage is read visually. The units are typically in feet, out to tenths (e.g., 602.7 ft.) or hundredths of a foot (e.g., 1.98 ft).

Your VLMP Coordinator can help you determine a good lake level benchmark and answer questions regarding staff gage installation or reading an already established gage at your lake.

Lake/Watershed Management: If lake and/or watershed management practices are being implemented, their effect on the quality of the lake may be seen in your Secchi disk readings and other observations and measurements. Include as much information as you are able to gather on when, where, how much, and what types of lake and watershed activities have occurred since your previous monitoring date. Such activities include aquatic herbicides used to control aquatic plants and algae; dredging; aquatic weed harvesting; shoreline erosion control work; fish stocking; and construction activities adjacent to the lake or in the watershed.

Additional Observations: Record on the Secchi Monitoring Form any additional observations such as odor, excessive plant or algae growth near shore, recreational usage, unusual activities in the lake's watershed, waterfowl and wildlife, etc.

Aquatic Exotics: Indicate which aquatic invasive species are present or that you suspect are present in the lake. If you conducted a special inspection for any aquatic invasive species, describe what you did in the Lake/ Watershed Management section [that is, which species you looked for; the areas of the lake in which you looked (e.g., by west shore boat launch; along north shore); what objects, if any, you inspected (e.g., concrete block “sampler,” rocks, buoys, dock posts, boat hulls, fishing gear, bait buckets, etc.) and where the objects were located; and whether or not you found (or suspect you found) any aquatic invasive species.] If you'd like to confirm a species' identification, refer to the AIS Monitoring and Specimen Preservation Tips section beginning on page 21 of this Manual for instructions on collecting, preserving, and submitting specimens.

Percentage of Lake that contains aquatic plants: Estimate the percentage of the lake's entire area (i.e., not just in the vicinity of the monitoring sites) that contains aquatic plants (both floating-leaved and submersed plant species). Indicate the

appropriate percentage range on the Secchi Monitoring Form. If you know the names of the plants present, write those down in the space provided.

TIPS: Aquatic plants with floating leaves (such as lilies, duckweeds, and some pondweeds) will be more easily seen than submersed plants (e.g., coontail, milfoil, naiads, several of the pondweeds) which may not grow tall enough to reach the water surface. You'll need to look more carefully into the water to see these. Polarized sunglasses may help. Determining to what depth plants are growing will help estimate their areal extent. Electronic "fish finders" can help provide an indication of submersed plant growth. Or, you can toss a rake attached to a rope into the water to pull up plants. (A rough rule of thumb is that there is enough sunlight to support plant growth to twice the Secchi disk transparency.) Sketching areas of plant growth on a lake map (especially a map that shows the lake's bottom contours) will help in estimating the percentage of the lake's area containing aquatic plants.

Volunteer Hours: Record the total amount of time (to the closest 1/2 hour) you spent monitoring—including time for preparation, travel, Secchi readings, sample collection and shipping, completion of monitoring forms, and on-line data entry. This information is requested in order to help demonstrate the significant contribution that volunteers like YOU are making to protect Illinois' lake resources!

Water Quality and Chlorophyll Sampling Programs: Fill in this section if you collected water samples as part of the Tier 2 or Tier 3 program.

D.O./Temp. taken?: Indicate whether or not you recorded dissolved oxygen (D.O.)/temperature profile measurements at any of the monitoring sites by circling "Y" (yes) or "N" (no) in the appropriate row. Remember to include any D.O./temperature data when you mail in your Secchi Monitoring Form.

Datasheet entered online?: Indicate whether or not you entered your Secchi Monitoring Form data and water sample collection information on Illinois EPA's online data entry system.

When You Return Home (Tier 1 Basic Program)

Clean-Up & Equipment Storage

- ✓ See page 85 for Secchi disk, color chart, and multi-plate zebra mussel sampler care and storage information.

Submitting Monitoring Data

1. Ensure you have completed filling out all sections on the Secchi Monitoring Form.
2. If you have access to the Internet, enter your Secchi Monitoring data on-line into Illinois EPA's VLMP database. Instructions are provided in Appendix A. (If you do not have Internet access, skip to Step #3 below.)

The web address for data entry is:

<http://dataservices.epa.illinois.gov/waBowSurfaceWater/Default.aspx>

My User Identification (ID) is: _____

My Password is: _____

3. To mail in your Secchi data, tear off the bottom, pink copy of the Secchi Monitoring Form to keep for your records (double-check that your writing came through dark enough to read on the pink copy). Then mail the white and yellow copies of the completed Secchi Monitoring Form to your VLMP Coordinator in one of the pre-addressed, postage-paid envelopes provided.

IMPORTANT NOTES:

- Even if you entered your monitoring data on-line, you must also mail in the white and yellow paper copies of your Secchi Monitoring Form to your Coordinator for quality assurance and data backup purposes.

- If you recorded D.O./temperature measurements as part of Tier 2 or Tier 3 monitoring, upload this data to the VLMP database (see instructions in Appendix A) and mail the original(s) of the D.O./Temperature Monitoring Form(s) to your Coordinator. (You may wish to make copies for your records).
 - If you recorded D.O./temperature measurements with you own equipment as part of Tier 1 monitoring, please mail a copy of the data to your Coordinator. Please indicate the brand and model of the dissolved oxygen meter you used.
4. If you'd like, you can also record your Secchi monitoring information on the Personal Record of Observations form (provided after page 92 in this Manual). Keeping a record for yourself on one sheet helps you easily track your lake monitoring activities, and it also safeguards the data in the event that the copies you send to your Coordinator are damaged or lost in the mail.
 5. If you're participating in the Tier 2 or Tier 3 Advanced Program, continue on to the *When You Return Home* section for the Advanced Programs later in this Training Manual (beginning on page 64) and follow those steps too.

TIER 2 AND TIER 3

The "Advanced" Programs (Water Chemistry Sampling, Chlorophyll Sampling, & Dissolved Oxygen/Temperature Measurements)

Laboratory Analyses

The water samples you collect are analyzed at an Illinois EPA or Illinois EPA-certified laboratory for several water quality indicators which are described below. More information can be found in *A Guide to Illinois Lake Management* (provided with this Training Manual), the *Lake Notes* fact sheet "Common Lake Water Quality Parameters" (<http://www.epa.state.il.us/water/conservation/lake-notes/quality-parameters.pdf>), and a University of Wisconsin-Extension publication *Understanding Lake Data* (<http://learningstore.uwex.edu/pdf/G3582.pdf>).

Suspended Solids

Suspended solids is a measure of the particulate matter in the water. Suspended solids includes soil particles, detritus resuspended from the lake bottom, free-floating (planktonic) algae and plant material—essentially, anything that can be "suspended" in the lake's water. Usually, the greater the amount of suspended solids in the lake, the less your Secchi disk transparency will be. Sources of suspended solids to your lake may include runoff from farms, streets, and lawns, as well as resuspended bottom sediment caused by motorboats, wind and waves, and the activity of bottom-feeding fish, such as carp. When the laboratory analyzes your sample for suspended solids, it actually makes two measurements: **total suspended solids**, which are ALL of the suspended solids, and **volatile suspended solids**, which represent that portion of the total suspended solids that is "volatile" (can be burned off in a hot laboratory oven). Volatile suspended solids are primarily organic in nature, and may consist of free-floating "planktonic" algae and/or organic detritus from the lake bottom.

Phosphorus

Phosphorus is particularly important to understanding your lake, because it is the nutrient that ultimately affects the amount of aquatic plant and algae growth in many Illinois lakes. An excess of phosphorus can lead to dense growth of aquatic plants or

even "pea soup green" blooms of algae. Sources of phosphorus to your lake may include fertilizers from agricultural fields and lawns, waterfowl waste, wastewater treatment plants, failing septic systems, and "regeneration" from bottom sediments. The laboratory analyzes your water sample for **total phosphorus**. This includes both phosphorus dissolved in the water as well as particulate phosphorus (which includes phosphorus in the tissue of microscopic plants and animals that might be suspended in the water). Researchers have found that total phosphorus concentrations above 0.030 mg/L are typically enough to stimulate nuisance algae growth. While Illinois' General Use Water Quality Standard for total phosphorus in lakes is 0.050 mg/L, levels above this standard are common among the state's many eutrophic (nutrient-rich) lakes.

Nitrogen

Nitrogen is the second most important nutrient (after phosphorus) that contributes to aquatic plant and algae problems in many Illinois lakes. Like phosphorus, sources of nitrogen to a lake may include fertilizers from farms and lawns, waterfowl, wastewater, failing septic systems, and regeneration from bottom sediments. But unlike phosphorus, nitrogen also is readily available from the atmosphere. "Blue-green" algae (often the species that form floating mats on the lake surface) are able to "use" nitrogen directly from the atmosphere. Hence, controlling sources of nitrogen to your lake may not necessarily limit the growth of algae the same way that controlling phosphorus can.

Your water sample is analyzed for three forms of nitrogen: 1) **total ammonia nitrogen** (an inorganic form of nitrogen; found in organic materials and many fertilizers; readily used by aquatic plants and algae; high ammonia concentrations can be toxic to fish and other aquatic organisms); 2) **nitrate+nitrite nitrogen** (inorganic forms of nitrogen; used by aquatic plants and algae; nitrate nitrogen is potentially toxic to infants when present in drinking water at high concentrations); and 3) **total Kjeldahl nitrogen** (total ammonia plus organic nitrogen). Researchers have found that inorganic nitrogen concentrations above 0.30 mg/L are able to stimulate algae growth.

Alkalinity

Alkalinity is a measure of the acid-neutralizing or "buffering" capacity of water. The higher a lake's alkalinity, the greater its resistance to a decline in pH. Alkalinity is commonly influenced by bicarbonates and thus is reported as the concentration of calcium carbonate (CaCO₃) in the water. Illinois lakes typically have high alkalinities and therefore are well-buffered from the effects of acid rain.

Chloride

Chloride is common in nature and, together with other dissolved minerals, determines the salinity ("saltiness") of water. Chloride is important in maintaining the salinity balance

of aquatic organisms and is required by algae and aquatic plants during photosynthesis. Illinois's General Use Water Quality Standards set a 500 mg/L level for the protection of aquatic life.

Chlorophyll

Under the Tier 3 program, as well as at select Tier 2 lakes, in addition to the water samples that you collect and send to the laboratory for analysis, you will collect an additional water sample that you will filter (upon your return home) for **chlorophyll** analysis. For this analysis, the filter paper is sent to the lab, not the filtered water. The filter paper will trap nearly all of the suspended material in the sample, including the microscopic algae cells. The lab will analyze the residue left on the filter paper for **chlorophyll a**, which is the green pigment present in all plant life and necessary for photosynthesis. The amount of chlorophyll *a* can be used to estimate the amount of “free-floating” algae (phytoplankton) in a lake, and it is therefore commonly used as an indicator of lake quality.

The residue on the filter paper is also analyzed for **chlorophyll b** and **chlorophyll c**. Analysis of these other chlorophyll pigments provides information on the various types of algae present. The blue-green algae contain only chlorophyll *a*, while the green algae and euglenoids contain both chlorophyll pigments *a* and *b*. The diatoms, golden algae, cryptomonads, and dinoflagellates contain chlorophyll pigments *a* and *c*. **Phaeophytin a** is also analyzed. This is a breakdown product of chlorophyll *a* that can interfere with its measurement, and so chlorophyll *a* is “corrected” for phaeophytin *a*. If a large amount of phaeophytin is present, it indicates a stressed algal population or recent algal dieoff.

Field Measurements

Dissolved Oxygen and Temperature

Dissolved oxygen (D.O.) and temperature measurements are taken by Tier 3 and select Tier 2 participants by using a probe attached to a cable and digital meter. The probe is lowered into the lake, and the dissolved oxygen concentration and water temperature is read and recorded at discrete depths from the water's surface down to near the lake bottom. These D.O./Temperature “profiles” show to what depth there is enough oxygen for aquatic organisms to survive (aquatic life generally needs at least 5 mg/L of dissolved oxygen), as well as if the lake is “stratified”—divided into horizontal layers of different temperature (and thus different density) water.

You'll find that as the sun begins to warm the lake surface through late spring and early summer, the temperature differences increase between the surface and deeper waters. In lake areas deeper than about 10–12 feet, the temperature differences eventually create a

physical force strong enough to resist the wind's mixing forces. The lake now stratifies into three layers of water—a situation called **summer stratification**. The upper layer is a warm (less dense), well-mixed zone called the **epilimnion**. Dissolved oxygen levels usually remain adequate for aquatic life within this zone, with high oxygen levels often occurring during algal blooms. On the other hand, a mass die-off of algae can cause depletion of D.O. as the algae decompose.

Below the epilimnion is a transitional zone called the **metalimnion** where temperatures rapidly change and dissolved oxygen levels may fluctuate. The **thermocline** is a horizontal plane within the metalimnion through the point of greatest water temperature change. Beneath the metalimnion and extending to the lake bottom is the colder (denser), usually dark, and relatively undisturbed **hypolimnion**. Just after summer stratification is established, the hypolimnion is rich in dissolved oxygen. However, because the metalimnion acts as a barrier between the epilimnion and hypolimnion, the hypolimnion is essentially cut off from oxygen exchange with the atmosphere and is often too dark for aquatic plants and algae to grow and produce oxygen by photosynthesis. In a nutrient-rich lake, the hypolimnion can become **anoxic** (without oxygen/anaerobic) as the summer progresses.

As autumn approaches and the surface waters begin to cool and sink as they become more dense, the metalimnion starts to break down. Eventually the whole lake reaches a similar temperature, and wind forces are able to mix the lake from top to bottom in a process called **fall turnover**. Algal blooms are often seen at fall turnover as nutrient-rich bottom water is brought to the lake surface where there is ample sunlight to support algae growth.

More information on this topic can be found in the *Lake Notes* fact sheet "Lake Stratification and Mixing" (<http://www.epa.state.il.us/water/conservation/lake-notes/lake-stratification.pdf>).

When to Sample

Collect your water samples for the Tier 2 program four times: **once each month from May through August**. For the Tier 3 program, collect your water samples five times: **once each month from May through August and again in October**. Water samples are always collected at the same time you conduct one of your "regular" Secchi disk transparency monitoring trips. However, water chemistry and chlorophyll samples must be collected on a **Sunday, Monday, Tuesday, or Wednesday**. This is because there's a short holding time on your samples, and it is important to plan ahead so that you can properly chill the samples and ship them in a timely manner. Ship samples the same day they are collected (if that is not possible, ship them no later than the next day). Keep in mind that **Wednesday is the last day during the week that samples can be shipped** to ensure that the samples will arrive and be checked in at the laboratory before the following weekend. Remember to **factor holidays into your sampling schedule** (Memorial Day, Fourth of July, Labor Day, Columbus Day) since there is no UPS pickup or delivery service on these days.

Where to Sample

Tier 2 Advanced Program water sampling is always conducted at your lake's "Representative Site" which is Site 1.

Tier 3 Advanced Program water sampling is also always conducted at Site 1. In addition, additional monitoring sites will be sampled as determined by your VLMP Coordinator and Illinois EPA.

Supplies and Equipment to Bring on the Boat

Tier 2 & Tier 3 – Water Chemistry:

- All equipment/supplies listed previously for the Tier 1 Basic Program (see pages 7–8)
- Half-gallon water sample collection bottle
- Sample bottle(s) without preservative (1 bottle for each site to be sampled)
- Sample bottle(s) containing preservative, with yellow tape across cap (1 bottle for each site to be sampled, plus an extra bottle)
CAUTION: These bottles contain sulfuric acid preservative* — **keep bottles upright!**
*Chemical safety information is provided on page 90 of this Manual.



NOTE: The size and/or shape of the unpreserved and preserved sample bottles may change from year to year.

- Cooler with plenty of ice (The cooler should be large enough to hold all your sample bottles so they can stand upright)
- Towel

Tier 3 – Water Chemistry

- Van Dorn water sampler (for near-bottom water sample collection)

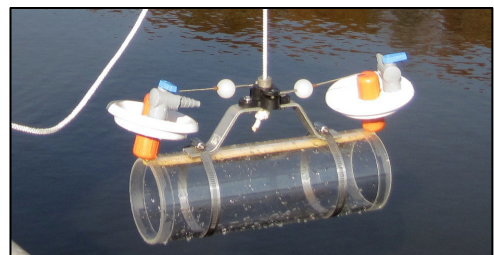

Tier 3 & select Tier 2 – Chlorophyll & D.O./Temperature:

- Half-gallon chlorophyll sample collection bottle (and a “with hole” bottle cap if necessary)
- Weighted bottle sampler with attached rope and clothespin
- Opaque, brown-colored, liter (quart)-sized bottle(s)
(1 bottle for each site to be sampled, plus an extra bottle)



- Handheld or boat-mounted electronic depth sounder



- Dissolved oxygen/ temperature meter (calibrated prior to each monitoring trip), and the appropriate number of “Dissolved Oxygen/ Temperature Profile” data forms (each form provides columns for 3 sites)



Dissolved Oxygen / Temperature Profile - Illinois EPA Lake Monitoring											
Lake Name		County Name		Volunteer Number		Name(s):		Date:		Inventor(s):	
Program: Volunteer Lakes				Name: (Print Name/Model or EPA Case/Number)							
Barometer Reading: _____ mm Hg				Station Code: _____				Station Code: _____			
Depth (feet)	DO (Heard to nearest 0.01)	Temp (F/deg)	Depth (feet)	DO (Heard to nearest 0.01)	Temp (F/deg)	Depth (feet)	DO (Heard to nearest 0.01)	Temp (F/deg)	Depth (feet)	DO (Heard to nearest 0.01)	Temp (F/deg)
0			0			0			0		
1			1			1			1		
3			3			3			3		
5			5			5			5		
7			7			7			7		
9			9			9			9		
11			11			11			11		
13			13			13			13		
15			15			15			15		
17			17			17			17		
19			19			19			19		
21			21			21			21		
23			23			23			23		
25			25			25			25		
27			27			27			27		
29			29			29			29		
31			31			31			31		
33			33			33			33		
35			35			35			35		
37			37			37			37		
39			39			39			39		
41			41			41			41		
43			43			43			43		
45			45			45			45		
47			47			47			47		
49			49			49			49		

Sample Bottle Labels

The **water chemistry sample bottles must be marked** with the Sample Container Field ID and Collection Date.

Write the Sample Container Field ID on each bottle **exactly** as it appears in the “Sample Container Field ID” box found in the upper right corner of your blue, water chemistry lab sheets. The Sample Container Field ID consists of your lake’s assigned 3- or 4-letter code, a dash, and then the site number (e.g., XYZ-1, XYZ-2, etc.).

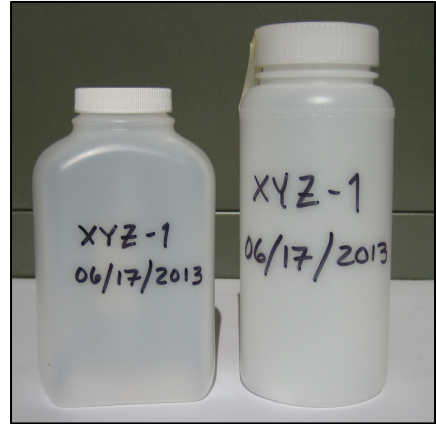

NOTE: In Tier 3, for sites where a both a near-surface and near-bottom sample are collected, the Sample Container Field ID will be followed by an “S” (for near-Surface sample) or “B” (for near-Bottom sample) (e.g., XYZ-1S, XYZ-1B).

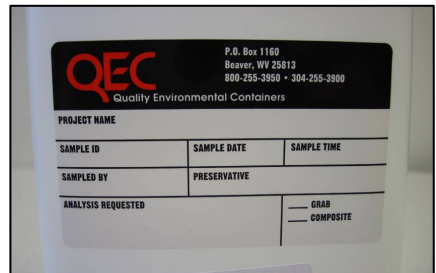

Write the **Collection Date** in month/day/year (mm/dd/yyyy) order (e.g., 06/17/2013).

IMPORTANT:

Write this information **before** putting the bottles into your cooler by either:

- a) directly writing on each bottle using a permanent marker, or
- b) using a ball point pen to write on an adhesive label that you then stick onto each bottle.

TIP:

For Tier 3, since you are collecting samples at other sites in addition to Site 1, use a permanent marker to write the appropriate site number on each bottle’s cap. Also mark the brown-colored chlorophyll sample bottles with the appropriate site number on the cap and side. This will help ensure you use the correct bottles for each site’s samples.



A Clean Boat

Before heading out onto the lake, make sure the sides and gunwales (top edge) of your boat are free of dirt and debris. Also remove dirt and debris from the interior of your boat. We certainly don't want to chance contaminating the water samples with materials that could be knocked or washed off your boat while you are monitoring.

On-Lake Procedures

Water Chemistry Sample Collection (Tier 2 & Tier 3)

After you arrive at the monitoring site (see *Where to Sample* on page 46), complete Steps #1 through #12 of the Tier 1 Basic Program (pages 8–14), then **STOP** before you proceed to Step #13 (measuring the site's total water depth, page 15).

1. Establish a “rinse” side and a “sample collection” side of the boat.
(Do not collect samples near the anchor line.)

2. Rinse your hands and forearms briskly in the water on the “rinse” side of the boat which is opposite from where you will sample. Don't use soap! (Many soaps contain phosphorus, and this would contaminate the samples.)



3. **Rinse the half-gallon water collection bottle** as follows:

On the “rinse” side of the boat (the same side where you rinsed your hands and forearms), immerse the half-gallon bottle, *with the cap on*, into the water.

Remove the cap under water with your other hand, and while keeping this hand away from the bottle opening, allow the bottle to fill about half way.

Replace the cap while the bottle is still under water.



Bring the bottle out of the water, shake the contents, remove the cap, discard the water on the “rinse” side of the boat, and replace the cap.



4. Collect the sample water as follows:

Move to the other side of the boat—to the “sample collection” side. Immerse the half-gallon bottle, *with the cap on*, down into the lake about **1 foot deep** (up to your elbow).



Remove the cap under water with your other hand, and while keeping this hand away from the bottle opening, allow the bottle to **fill completely** this time.



TIP: In order for the bottle to fill as completely as possible, it may help to hold the bottle generally parallel to the water surface (e.g., a quarter turn upwards) rather than vertically (up and down) in the water column.

Replace the cap while the collection bottle is still under water, then bring the collection bottle up into the boat.

NOTE: Keeping the cap on the half-gallon water collection bottle as it is taken into and out of the water prevents the collection of oils and algae scums that may be present on the water surface.

5. Gently **invert the half-gallon collection bottle a few times** so that the water is well mixed. Remove the half-gallon bottle's cap and set it aside with its inside portion facing up.

6. Take the two sample bottles (1 preserved, 1 unpreserved) out of the cooler and keep the bottles upright. ***Never rinse these sample bottles!***

Taking the preserved bottle first, unscrew its cap and set the cap aside with its inside portion facing up. Be careful to keep the inside of the cap from getting contaminated. (If the cap does get soiled, you can rinse the cap in the lake on the “rinse” side of the boat.)

NOTE: The yellow caution tape placed over the preserved bottle's cap will easily break, but please do not remove the tape from this bottle.

Slowly pour the water from the half-gallon collection bottle into the preserved sample bottle. **Fill the sample bottle to just under its shoulder**—but **don't overfill the preserved bottle!** This is important because each yellow-taped bottle contains a liquid preservative (sulfuric acid) that will be diluted or washed out if the bottle is overfilled.

Recap the preserved sample bottle tightly and gently rotate/invert the sample bottle to ensure the preservative is well-mixed with the sample water.

Then follow the same procedure to fill the unpreserved sample bottle.



IMPORTANT NOTES:

- Both the preserved and unpreserved sample bottles must be filled from the same half-gallon water collection.
- Fill the preserved sample bottle first. This is because if the preserved bottle is overfilled, that bottle cannot be used and must be discarded. Because both sample bottles must be filled from the same half-gallon collection, there won't be enough water left in the half-gallon collection bottle to fill both a new, preserved sample bottle and the unpreserved sample bottle.
- If you overfill the preserved bottle, mark a big "X" across its label and set it aside for later disposal. Write the appropriate SAMPLE ID on a new preserved bottle. Pour out the lake water that's still in the half-gallon collection bottle on the "rinse" side of the boat, then go back to Step #4 on page 50 to refill the half-gallon collection bottle on the "sample collection" side of the boat.

CAUTION: If you accidentally get any of the preservative on your skin or clothing, immediately turn to the section of this Training Manual entitled "Chemical Safety Information" (page 90) and follow the instructions.

7. Immediately place the two sample bottles into a cooler with ice. Close the lid so no sunlight reaches the samples.

IMPORTANT NOTE:

Push the bottles into the ice so they are **upright** and **surrounded by ice**. Do not just place the bottles on top of the ice.



8. Discard any remaining water in the half-gallon collection bottle on the "rinse" side of the boat.

Near-bottom Water Chemistry Sample Collection (Tier 3)

See the instructions in Appendix B for using the Van Dorn sampler.

Chlorophyll Sample Collection (Tier 3 and select Tier 2)

Prepare to collect the chlorophyll sample as follows:

9. Check the water depth again using a handheld or boat-mounted electronic depth sounder.



IMPORTANT NOTES:

- **The chlorophyll sampling depth will be to TWICE the Secchi transparency (to the nearest foot*)** — unless the lake is not deep enough at the monitoring site or if aquatic plants might interfere with sample collection (see below).

For example:

If Secchi disk depth = 32"

Then Chlorophyll sampling depth would be 64"

But Chlorophyll samples should be collected (and recorded) to the closest foot

Therefore. . . 64 inches = 5 feet, 4 inches. When rounded to the nearest foot, you'd collect to—and record the sample depth as—5 feet.

BUT...

- If your lake (at the sampling site) is not as deep as twice the Secchi depth, then you will collect the sample down to 2 feet above the lake bottom.

For example:

If Secchi disk depth = 72" (6 ft.)

Then Chlorophyll sampling depth would be 144" (12 ft.)

But Total water depth at this site is only 10 ft.

Therefore. . . Chlorophyll sampling depth is 8 ft. (10 ft. – 2 ft. = 8 ft.)

OR...

- At some monitoring sites, aquatic plants may limit how deep you can collect the chlorophyll sample without touching the plants. It's better

to err on the side of caution and collect the chlorophyll sample a little shallower than you might otherwise if no aquatic plants were present.

* In all cases, ***collect the chlorophyll sample to the nearest foot.*** And be sure to record the chlorophyll sample collection depth on the Secchi Monitoring Form and chlorophyll lab sheet.

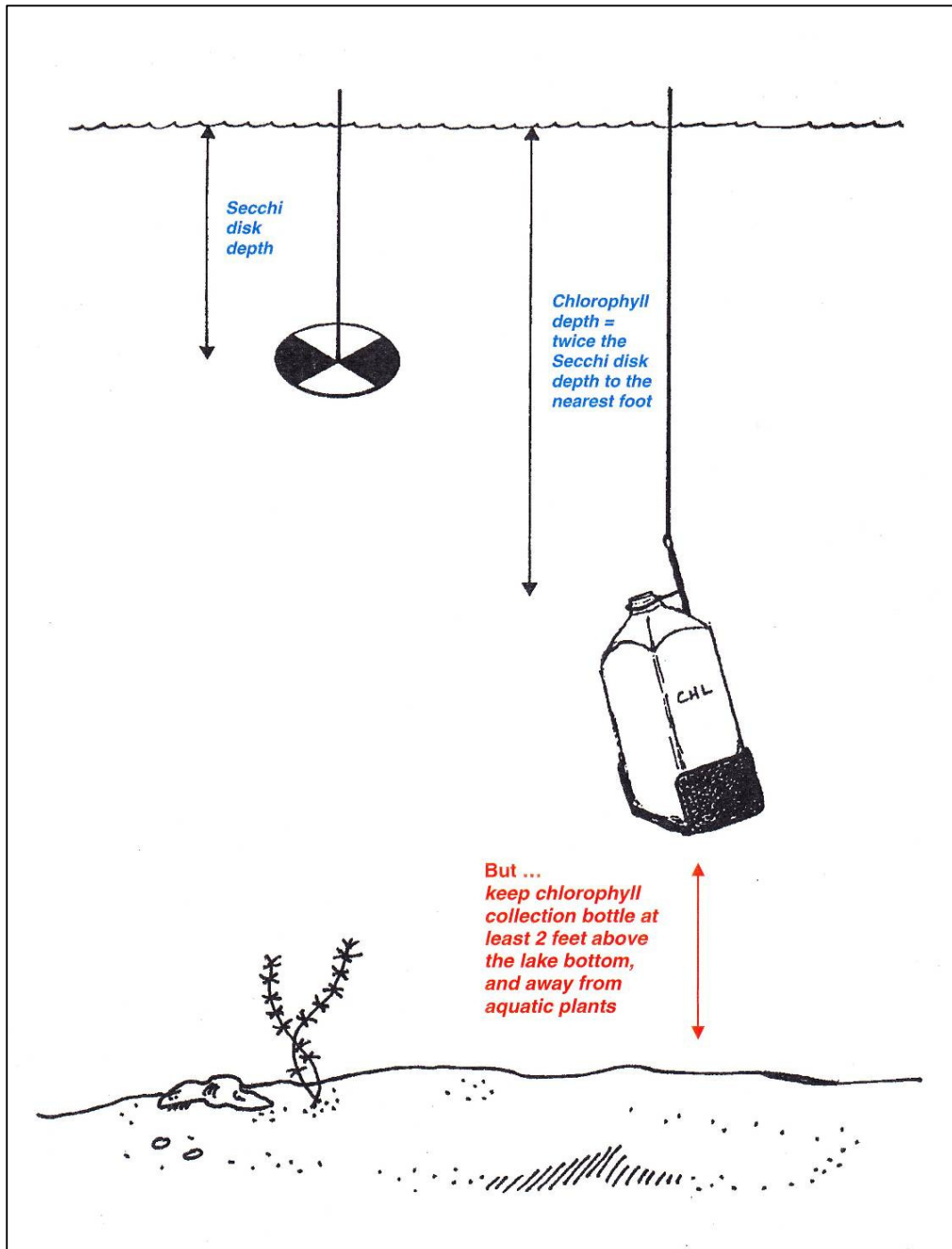

10. Take the clothespin and place it on the weighted bottle sampler's rope at the "twice the Secchi transparency to the nearest foot" depth (or at the "2 feet off the bottom or above aquatic plants" depth—see instructions above).
11. Place the half-gallon chlorophyll collection bottle into the weighted bottle sampler. Remove the bottle cap.
12. Rinse the chlorophyll collection bottle by lowering the bottle a foot or two into the lake on the "rinse" side of the boat (the same side where you rinsed your hands and arms earlier). If there is a surface scum, break it up by "bouncing" the weighted bottle sampler on the water surface a few times.



Allow the bottle to fill about half way, pull the bottle back up, shake the contents, and discard the rinse water into the lake (again, all this is done on the side of the boat opposite from where you will be collecting your sample).

NOTE: You may also rinse the chlorophyll collection bottle using the same procedure for rinsing the water chemistry sample collection bottle (as explained in Step #3 above).



13. Collect the sample water as follows:

IMPORTANT NOTE:

If your chlorophyll sampling depth is 12 feet or more, then screw the cap with the hole in it onto the half-gallon collection bottle. This special cap slows down the rate at which the bottle fills, allowing for a more precise sample.



Move to the “sample collection” side of the boat. If there is a surface scum, break it up by “bouncing” the weighted bottle sampler on the water surface a few times.

In one continuous motion, lower the bottle at a steady pace to the depth marked by the clothespin, then raise the bottle back up at a similar steady rate. **Do not pause or stop** anywhere along the way!



It may be necessary to lower and raise the bottle more than once. Continue at a steady lowering/raising pace until the bottle is **one-half to two-thirds (1/2 to 2/3) full**.

IMPORTANT NOTES:

- If the collection bottle is completely (or even nearly completely) full after you pull it up, you must discard the water (on the opposite/ “rinse” side of the boat) and start over. This is because the bottle filled up with water at some point before you got it back up to the lake surface, and thus the sample will not be equally representative of the whole water column. If you are ever in doubt, start over.
- As you lower and raise the weighted bottle sampler, never let it touch the lake bottom or rub against aquatic plants!

14. Bring the weighted bottle sampler into the boat. Place the solid cap on the half-gallon bottle and tighten, then remove the bottle from the sampler. **Gently invert the half-gallon bottle several times to ensure the water is well mixed.**
15. Take the brown-colored chlorophyll sample bottle out of the cooler, remove its cap, and set the cap aside with its inside facing up. (*Never rinse the brown-colored chlorophyll sample bottle!*) Remove the half-gallon bottle's cap in the same manner.
16. Slowly pour the water from the half-gallon bottle into the brown-colored bottle. Fill the brown-colored bottle to near its shoulder, being careful not to overfill it. This is important because the brown-colored bottle contains a powdered preservative (magnesium carbonate) that can be washed out if the bottle is overfilled.



IMPORTANT NOTE:

If you overfill the brown-colored bottle, mark a big “X” on its cap and side and set it aside for later disposal. Get out a new brown-colored bottle. Pour out any lake water that’s still in the half-gallon collection bottle on the “rinse” side of the boat, then go back to Step #13 above to refill the half-gallon collection bottle on the “sample collection” side of the boat.

17. Recap the brown-colored bottle tightly.
18. Gently rotate/invert the brown-colored bottle several times to ensure the preservative is well mixed.



19. Immediately place the brown-colored bottle into a cooler in ice. Close the lid so no sunlight gets into the cooler.



20. Discard any remaining water in the half-gallon collection bottle on the “rinse” side of the boat.

Dissolved Oxygen/Temperature Measurements (Tier 3 & select Tier 2)

If you have *not* already calibrated the Hach HQ Series dissolved oxygen (D.O.)/temperature meter, you will need to do so now before taking in-lake measurements, following the calibration instructions provided with the meter in its carrying case (and also provided in this Manual beginning on page 97).

IMPORTANT NOTES:

- You will be recording D.O./temperature readings at just under the lake surface (“0” feet deep), at 1 foot deep, and then at every other foot (3, 5, 7 ft., etc.) down to 2 feet above the lake bottom. The last measurement might be at an “even numbered” depth.

FOR EXAMPLE:

If Total depth at site = 15 ft.

Then Record D.O./temperature readings at 0, 1, 3, 5, 7, 9, 11, and 13 ft. deep

BUT:

If Total depth at site = 14 ft.

Then Record D.O./temperature readings at 0, 1, 3, 5, 7, 9, 11, and 12 ft. deep

- It is extremely important to protect the probe from damage. Do NOT allow the probe to touch the lake bottom!
- Some of the cables have been marked with tape at every foot (1, 2, 3, 4, 5, 6 ft., etc.) while other cables have a tape mark at every other foot (1, 3, 5, 7, 9 ft. etc.).
- The maximum depth at which data can be recorded is 49 feet, since the cable is about 50 feet long. Do NOT immerse the meter in the lake — it is not waterproof!

21. Record D.O./temperature measurements as follows:

- A. Turn on the dissolved oxygen/temperature meter. Ensure the cable is securely attached to the meter.

Power ON/OFF button

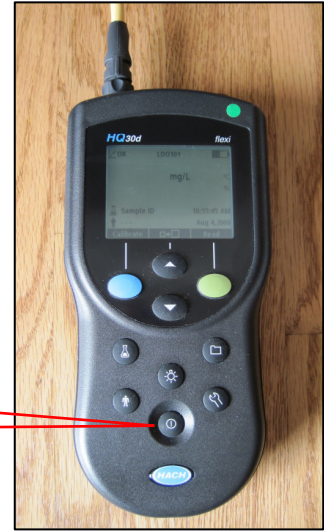

- B. Check the water depth again using the handheld depth sounder.



- C. Write in the required information at the top of the “Dissolved Oxygen/Temperature Profile” data form (refer to the example form below).

Lake Name and County: if not already pre-printed on the form, write in your lake’s name and the county in the appropriate space.

Barometer Reading: this number was displayed in the lower right corner of the Hach meter’s “Calibration Summary” screen after you were “Done” with the calibration; the barometric (atmospheric) pressure will be displayed again on the screen after you take your first D.O./temperature reading.

Volunteer Name(s): first and last name; list the volunteer reading the meter first.

Date: in month, day, year order (e.g., 06/15/2010).

Meter Brand/Model: the manufacturer and model of the meter you are using (e.g., Hach HQ30d, Hydrolab Quanta, YSI 550A).

IEPA Case/Meter #: either the number written on the meter’s storage case, or the Illinois EPA inventory tag number affixed to the back of the meter.

Station Code: if not already pre-printed on the form, this consists of your lake's 3- or 4-letter code, a dash, and then the site number (e.g., XYZ-1, XYZ-2, XYZ-3).

Time: in 24-hour (hh:mm) format (i.e., 1:00 a.m. - 12:00 noon = 01:00 - 12:00 hours, but 1:00 p.m. - 12:00 midnight = 13:00 - 24:00 hours).

- D. The **Depth** (in whole numbers) for each D.O./temperature reading has been pre-printed on the form. Remember, you will only take readings down to 2 feet above the lake bottom (refer to Important Notes on page 59). If the last measurement is at an even numbered depth, cross out that pre-printed depth and write in the actual depth.

Dissolved Oxygen / Temperature Profile - Illinois EPA Lake Monitoring								
Lake Name		County Name		Volunteer				
Program: Volunteer Lakes		Barometer Reading: _____ mm Hg		Name(s): _____ Date: ____/____/____ (mm:dd:yyyy)				
Station Code: _____		Station Code: _____		Station Code: _____				
Time: _____		Time: _____		Time: _____				
Depth (feet)	DO (Round to nearest 10th)	Temp	Depth (feet)	DO (Round to nearest 10th)	Temp	Depth (feet)	DO (Round to nearest 10th)	Temp
0	.	.	0	.	.	0	.	.
1	.	.	1	.	.	1	.	.
3	.	.	3	.	.	3	.	.
5	.	.	5	.	.	5	.	.
7	.	.	7	.	.	7	.	.
9	.	.	9	.	.	9	.	.
11	.	.	11	.	.	11	.	.
13	.	.	13	.	.	13	.	.
15	.	.	15	.	.	15	.	.
17	.	.	17	.	.	17	.	.
19	.	.	19	.	.	19	.	.
21	.	.	21	.	.	21	.	.
23	.	.	23	.	.	23	.	.
25	.	.	25	.	.	25	.	.
27	.	.	27	.	.	27	.	.
29	.	.	29	.	.	29	.	.
31	.	.	31	.	.	31	.	.
33	.	.	33	.	.	33	.	.
35	.	.	35	.	.	35	.	.
37	.	.	37	.	.	37	.	.
39	.	.	39	.	.	39	.	.
41	.	.	41	.	.	41	.	.
43	.	.	43	.	.	43	.	.
45	.	.	45	.	.	45	.	.
47	.	.	47	.	.	47	.	.
49	.	.	49	.	.	49	.	.

- E. Place the probe into the lake. Make sure the tip of the probe is under the water surface by immersing the probe to the top of the protective shroud's locking ring. (This is the "0" depth.)



- F. Press the GREEN button (under "Read" on the meter's display screen).



The screen will display "Stabilizing..." and a progress bar will fill from 0 to 100% as the reading stabilizes. When the reading has stabilized, the meter will beep and a padlock icon will appear in the upper left corner on the screen.

- G. Record the displayed D.O. and temperature readings on the data form, rounding to the nearest tenth (i.e., one decimal place; for example, record D.O. as 8.8, not 8.75). The D.O. is displayed in mg/L (milligrams per liter), and the temperature is in °C (degrees Celcius).



TIPS:

- Pressing the “Up” arrow button that is located below the center of the display screen toggles the size of the lettering on the screen between small and large lettering.
- Pressing the “Light Bulb” button turns a backlight on and off.



- H. **Repeat Steps F and G** after lowering the probe to the 1 foot depth (denoted by the first tape mark on the meter’s cable), and then to every other foot thereafter (3, 5, 7 feet deep, etc.), down to 2 feet above the lake bottom (which may be an “even numbered” depth).
- I. After recording the final D.O./temperature measurement at each monitoring site, turn off the meter to conserve battery power.
22. **Return to Step #13 of the Tier 1 Basic Program** (measuring the site’s total water depth, page 15 of this Manual).

When You Return Home (Tier 2 and Tier 3)

1. SAMPLE BOTTLE LABELS

Ensure the Sample Container Field ID and Collection Date are still legible on the water chemistry sample bottles. If you need to re-write any of this information, dry off the bottle or adhesive label with a terry cloth or paper towel before re-writing. (Refer to page 48 for complete instructions.)

2. TEMPORARY WATER SAMPLE STORAGE

The **water chemistry sample bottles must be kept cold** and therefore must remain surrounded by ice in your cooler for at least 1 hour *and* until you are ready to pack and ship the samples to the lab. You may need to add more ice to the cooler. Be sure the bottles remain upright and that the tops of the bottles remain above the ice. Also, do not let the bottles become submersed in ice water (so there's no chance of sample contamination due to seepage around the bottle caps.)

Ship the same day of collection. If this is absolutely not possible, ship no later than the next day, and never later than a Wednesday.

3. FILL OUT WATER CHEMISTRY LAB FORM

Complete the appropriate spaces on the **blue** lab form (refer to the instructions and example form found below or provided by your Coordinator).

Collected By: your first and last name.

Sample Container Field ID: if not already pre-printed on your lab form, this consists of your lake's 3- or 4-letter code, a dash, and then the site number (e.g., XYZ-1, XYZ-2, etc.).

Note: for monitoring sites where water chemistry samples are being collected at both the 1-foot depth and near the lake bottom, an "S" (for near-Surface) and a "B" (for near-Bottom) are added after the site number on the respective lab forms (e.g., XYZ-1S, XYZ-1B).

Station Code: if not already pre-printed on your lab form, this consists of your lake's 3- or 4-letter code, a dash, and then the site number (e.g., XYZ-1).

Waterbody Name and County: if not already pre-printed on your lab form, write in your lake's name and the county on the appropriate line.

Collection Date: write in month, day, and year (e.g., 06/15/2010).

Collection Time: in "24-hour" (hh:mm) format (i.e., 1:00 a.m - 12:00 noon = 01:00 - 12:00 hours; but 1:00 p.m. - 12:00 midnight = 13:00 - 24:00 hours).

Trip ID: if not already pre-printed, this consists of the year, the letters "VLMP," and the words "Visit No: 001" (e.g., 2010VLMP Visit No: 001).

Comments: At the bottom of the lab form is space for any comments, if applicable (e.g., unusual lake conditions, weather).

Illinois EPA - Bureau of Water - Surface Water Section

Request for Laboratory Analysis

Sample-Group Number (For Laboratory Use Only): _____

Collected By: _____ Sample Container Field ID: _____

Station Code: _____

Waterbody Name: _____

County: _____ Sample Depth (ft): **1.0 ft.**

Collection Date: ____/____/____ (mm) (dd) (yyyy)

Collection Time: 24-Hour (hh:mm) ____ : ____

Trip ID: **2 0 0 9 V L M P** Visit No: **0 0 1**

Sample Container	Run	Parameter	Method
1-l. liter HDPE	X	Alkalinity	SM 2320B
	X	Chloride	USEPA 325.2/ 9251
	X	Total Suspended Solids	USEPA 160.2
	X	Volatile Suspended Solids	USEPA 160.4
	X	Nitrogen, nitrite+nitrate (total)	USEPA 353.2
1-Liter HDPE	X	Phosphorus (total)	USEPA 365.1
	X	Nitrogen, ammonia (total)	USEPA 350.1; 350.3
	X	Nitrogen, Kjeldahl (total)	USEPA 351.2

Funding Code: WP85
Monitoring Unit: n/a
Sample Medium: Water
Laboratory: Prairie Analytical
Surface Water Monitoring Program: Volunteer Lakes

Surface Water Section Contact Information:
VLMP Contact: Sandy Nickel
Telephone: 217-782-3362
Email: sandy.nickel@illinois.gov
QA/QC Contact: Mike Henebry
Telephone: 217-785-3944
Email: mike.henebry@illinois.gov

Please Return This Sheet To:
Illinois Environmental Protection Agency
Surface Water Section #15
1021 North Grand Avenue East
Springfield, Illinois 62794-9276

Comments: _____

updated March 26, 2009

4. COMPLETE THE SECCHI MONITORING FORM

In the lower left corner of your Secchi Monitoring Form in the “Water Quality and Chlorophyll Sampling Programs” section, mark the appropriate boxes to indicate which samples you collected today and the date that the samples will be shipped.

Note: The lake water in the sample bottle containing acid preservative is analyzed for ammonia, TKN, and TP. The water in the unpreserved (w/o acid) bottle is analyzed for suspended solids, alkalinity, chloride, and nitrate+ nitrite nitrogen.

Water Quality and Chlorophyll Sampling Programs						
Indicate bottles collected	Bottle w/o Acid	Bottle w/Acid	Chlorophyll (a, b, c & pheophytin)			
	TSS/VSS, Alkalinity, Chloride, N-ate/ite	TP, TKN, Ammonia	1 Liter Bottle	Sample Depth	Amount Filtered	
1	<input type="checkbox"/>	<input type="checkbox"/>	<input type="checkbox"/>	ft	ml	
2	<input type="checkbox"/>	<input type="checkbox"/>	<input type="checkbox"/>	ft	ml	
3	<input type="checkbox"/>	<input type="checkbox"/>	<input type="checkbox"/>	ft	ml	
	<input type="checkbox"/>	<input type="checkbox"/>	<input type="checkbox"/>	ft	ml	
	<input type="checkbox"/>	<input type="checkbox"/>	<input type="checkbox"/>	ft	ml	

Date Mailed: _____

IL 632-0941
WPC 068b Rev. 06/12 Volunteers - Retain PINK copy

5. WATER CHEMISTRY SAMPLING EQUIPMENT CLEAN-UP & STORAGE

See pages 85–86 for equipment care and storage instructions.

6. FILTER CHLOROPHYLL SAMPLE (TIER 3 & select TIER 2)

After you get back to shore you need to immediately filter your chlorophyll sample(s), preferably in your home, office, or a nearby building. If this is not feasible, pick a comfortable location that is in the shade and out of the wind.

Make sure you have all your chlorophyll filtering equipment and supplies handy.



- A. Attach the plastic tubing to the hand pump (if it isn't already attached) and to the spout on the plastic flask.

Make sure to push the tubing over the two raised rings on the spout to make a good seal.

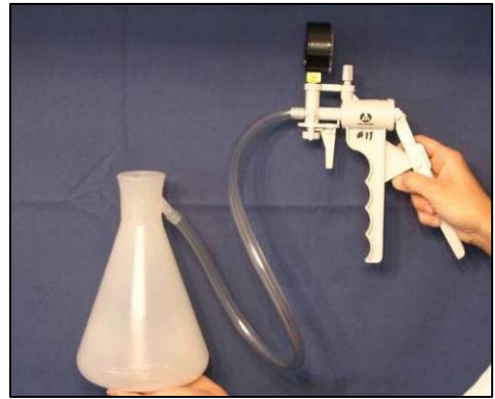

- B. Using the wash bottle (filled with fresh tap water) or under a faucet, rinse the lower portion of the magnetic filter funnel (the filter base with the black screen and rubber stopper).

NOTE: Using tap water (including well water) for rinsing is fine. Distilled or deionized water may also be used.



Push the stopper end into the top of the plastic flask. Wetting the stopper first helps to make a good seal.

IMPORTANT NOTES:

- Do NOT touch the filter screen with your fingers.
- When inserting the stopper into the filter flask, push down on the stopper itself. Do NOT push down on top of the filter base (the part with the black screen) because it could break.



- C. Using the tweezers, carefully remove one filter from the reclosable bag of filters.

NOTE: There is no top or bottom side to the filters.

Place the filter exactly in the center of the black filter screen.

CAUTION: *Do NOT touch the filter with your fingers while removing the filter from the bag or placing it on the screen! Do NOT touch the filter screen with your fingers.*

You might need to squirt a small amount of fresh tap water onto the filter to ensure that the entire filter becomes moistened. If you need to move the filter slightly to center it on the screen, do so by gently and carefully using the tweezers to grip the edge of the filter and reposition it. If the filter tears, punctures, or creases (or is dropped), use a new filter.

- D. Rinse the tinted plastic funnel cup (the part with the magnet) with fresh tap water.

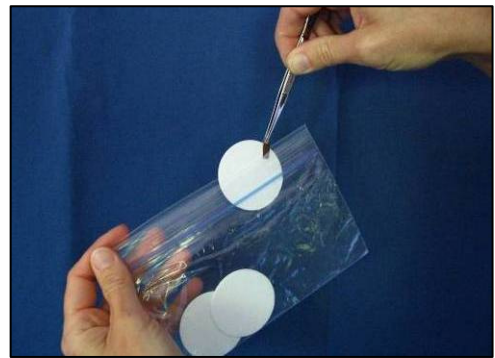

- E. Carefully align the funnel cup on top of the filter base. This cup has a strong magnet at the bottom and will quickly connect to the base. Be sure that the filter does not move, and that the funnel cup doesn't come in contact with the middle area of the filter.



- F. Rinse the graduated cone with fresh tap water.



- G. Take the brown-colored chlorophyll sample bottle out of your cooler and mix the sample gently by turning it upside down several times.



- H. Set the graduated cone on a flat and level surface. Fill the graduated cone with sample water exactly to the 500 mL mark. Move your head to cone level so that your eyes are on the same plane as the 500 mL mark. Add to or remove water from the graduated cone

(you can pour sample water back into the chlorophyll sample bottle) until the water line is exactly at 500 mL.

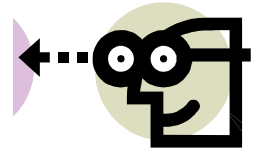

IMPORTANT NOTES:

- The objective is to filter as much water as reasonably possible without clogging the filter and thereby leaving unfiltered water in the funnel cup.
- If you filter less than the original 500 mLs in the graduated cone, you will be able to determine how much water you actually filtered by subtracting the amount of water remaining in the graduated cone from 500 mL. (DO NOT use the mL markings on the tinted funnel cup for determining volume of water filtered!)
- If you are able to filter all 500 mLs and think you can filter more sample water, you will need to fill the graduated cone again. However, you will not be able to fill the cone to the 500 mL mark this time since the brown-colored chlorophyll sample bottle holds a little less than 1000 mL. Therefore, fill the graduated cone so the water level is even with one of the graduations (e.g., the 400 mL mark), and make note of it. Be sure to keep track of the total volume of sample water you pour from the graduated cone into the funnel cup.

- I. To begin filtering, pour some of the water from the graduated cone into the funnel cup.



Squeeze the hand pump to create a vacuum suction (this moves the water through the filter).

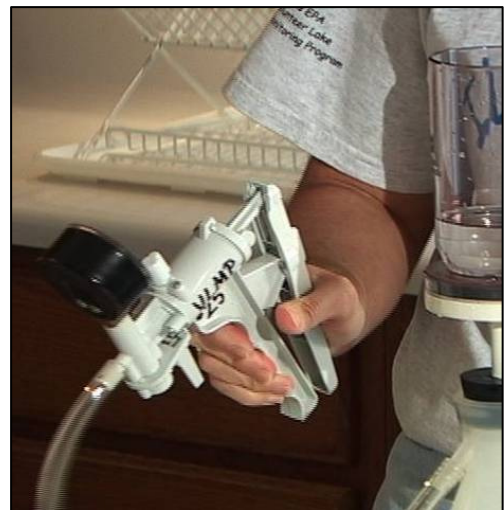

IMPORTANT NOTES:

- While the objective is to filter as much water as reasonably possible without clogging the filter and leaving unfiltered water in the funnel cup, DO NOT apply more than "15 inches" of vacuum pressure as measured on the outer scale of the pump's gauge. Even better, try not to surpass "10 inches" of vacuum. Excessive vacuum pressure will burst the algae cells and ruin your sample.

Never exceed 15 inches of pressure as measured on the outer scale of the vacuum pump's gauge



Even better, try not to exceed 10 inches of vacuum pressure

- As the filtering slows, you will want to add smaller amounts of water. It is extremely important that you filter ALL of the sample water that you pour into the funnel cup. NEVER pour any water back out of the funnel cup.
- If filtering really slows down, be patient and let the water drip through slowly, being careful not to exceed 15 inches of vacuum pressure.
- If the filter becomes fully clogged and any water left in the funnel cup cannot pass through, you will have to start the entire process over at Step #6B (page 67).

TIP: When the vacuum pressure reaches “10 inches” as read on the gauge’s outer scale, this is the point where you don’t want to add too much more sample water to filter, if any.

- J. When you're done filtering the sample, use your squirt bottle and "wash down" the sides of the funnel cup with small amounts of water. Some algae may have stuck to the sides of the cup, and this needs to get down to the filter paper.

TIP: A few small rinses are better than one big rinse.

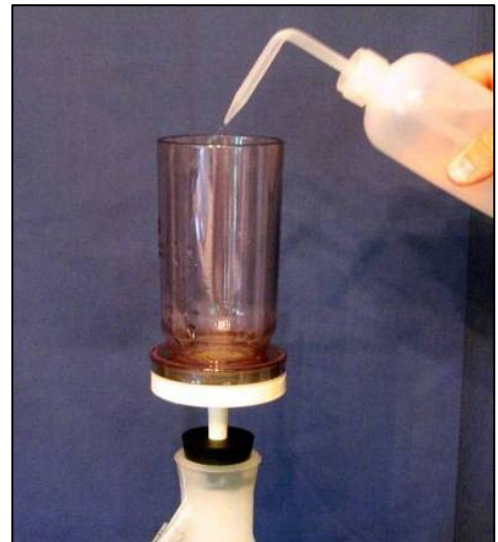

Apply additional vacuum suction as needed to completely pull the "wash water" through the filter (again, do not exceed 10–15 inches of vacuum pressure).

TIP: Now is a good time to fill out the chlorophyll sample label (see Step #7 on page 75).

- K. When the vacuum suction has pulled all the wash water through and the filter looks relatively "dry," release the vacuum pressure by pulling on the hand pump's trigger.



Then carefully push the rubber stopper slightly off the flask to release all remaining vacuum.



- L. While holding onto the filter base with one hand, carefully lift the funnel cup off, up, and away from the filter base with the other hand.

- M. Without removing the filter from the screen, use the tweezers to fold the filter in half (so that the algae is on the inside).

Use the "modified" paper clip (supplied with your chlorophyll kit) to help hold the filter in place while you gently fold it.



CAUTION: *Do NOT touch the filter with your fingers. The tweezers and paper clip should NEVER touch the filtered algae.*

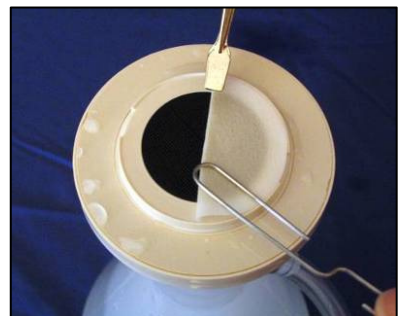

- N. Using the tweezers, fold the filter in half again.

Remove the filter from the filter screen with the tweezers.

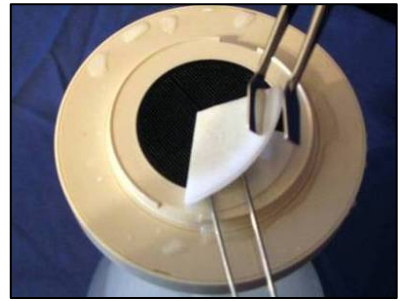

Place the filter on a piece of aluminum foil.



Fold each edge of the aluminum foil around the filter to form a closed packet.

TIP: If you place the filter just above the center of the aluminum foil strip, you can fold the foil in half over the filter, and then fold down the three open edges.



7. CHLOROPHYLL SAMPLE LABEL & TEMPORARY SAMPLE STORAGE

- A. Using a ballpoint ink pen (not felt tip), fill out the requested information on a green Chlorophyll Sample Filter label. Attach the label directly to the special chlorophyll sample reclosable baggie.

<p>CHLOROPHYLL SAMPLE FILTER <i>(affix this label to reclosable baggie)</i></p> <p>Sample Container ID: _____</p> <p>Amount of sample filtered: _____ mL</p>

Sample Container ID: this consists of your lake's code, a dash, and the site # (e.g., XYZ-1).

Amount of sample filtered: this is the amount, in milliliters (mL), of sample water you filtered.

IMPORTANT NOTE: Record only the volume of sample that you actually filtered (see previous discussion in Step #6H, page 70).

- B. Place the aluminum foil packet inside the reclosable baggie and close the baggie's seal completely.
- C. Rubber band the baggie containing the foil packet to a large, frozen ice pack (use two rubber bands, one to each side of the foil packet).



Place the ice pack with the attached baggie into a freezer for at least 1 hour and until you are ready to pack and ship to the lab.

NOTE: If a freezer is not available, sandwich the baggie between two frozen ice packs in a closed cooler out of the sun.

Place extra ice packs in the cooler to help keep things cold.



IMPORTANT NOTE: Ice packs must be in your freezer for at least 24 hours to reach a maximum chilled condition.

8. FILL OUT CHLOROPHYLL LAB FORM

Complete the appropriate spaces on the **green** lab form. This lab form is similar to the one you filled out for the water sample bottles, except you also need to record the **Chlorophyll Sample Depth** (to the nearest foot) and the **Volume Filtered** (refer to the instructions and example lab form below).

Collected By: your first and last name.

Sample Container Field ID: if not already pre-printed on your lab form, this consists of your lake's 3- or 4-letter code, a dash, and then the site number (e.g., XYZ-1).

Station Code: if not already pre-printed on your lab form, this consists of your lake's 3- or 4-letter code, a dash, and then the site number (e.g., XYZ-1).

Waterbody Name and County: if not already pre-printed on your lab form, write in your lake's name and the county on the appropriate line.

Collection Date: write in month, day, and year (e.g., 06/15/2010).

Collection Time: in "24-hour" (hh:mm) format (i.e., 1:00 a.m. - 12:00 noon = 01:00 - 12:00 hours; but 1:00 p.m. - 12:00 midnight = 13:00 - 24:00 hours).

Chlorophyll Sample Depth: write in the depth to which you collected the chlorophyll sample (to the nearest foot).

Trip ID: if not already pre-printed, this consists of the year, the letters "VLMP," and the words "Visit No: 001" (e.g., 2010VLMP Visit No: 001).

Chlorophyll Volume Filtered: write in the total milliliters (mLs) of sample you filtered (this must be identical to what you wrote on the Chlorophyll Sample Filter label).

Comments: At the bottom of the lab form is space for any comments, if applicable (e.g., unusual lake conditions, weather).

Request for Laboratory Analysis Illinois EPA - Bureau of Water - Surface Water Section

Sample-Group Number (For Laboratory Use Only): _____ Collected By: _____ Sample Container Field ID: _____

Station Code: _____

Waterbody Name: _____

County: _____

Collection Date: ____/____/____ (mm) (dd) (yyyy) **Chlorophyll Sample Depth: _____ 0 ft.**

Collection Time: 24-Hour (hh:mm) ____ : ____

Trip ID: 2 0 0 9 V L M P Visit No: 0 0 1

Sample Container	Run	Parameter	Method	Funding Code: WP06
Foil in Plastic Bag	X	Chlorophyll Volume Filtered (ml):	SM 10200H	Monitoring Unit: n/a
				Sample Medium: Water
				Laboratory: Springfield
				Surface Water Monitoring Program: Volunteer Lakes

Surface Water Section Contact Information:

VLMP Contact: Sandy Nickel
Telephone: 217-782-3362
Email: sandy.nickel@illinois.gov

QA/QC Contact: Mike Henebry
Telephone: 217-785-3944
Email: mike.henebry@illinois.gov

Please Return This Sheet To:
Illinois Environmental Protection Agency
Surface Water Section #15
1021 North Grand Avenue East
Springfield, Illinois 62794-9276

Comments: _____

updated March 26, 2009

9. REPEAT the above steps for each chlorophyll sample you collected.

NOTE: Before filtering another chlorophyll sample, empty the filter flask by pouring the water out of the flask's mouth opposite the spout (away from the tubing so water does not get into the vacuum pump).



10. COMPLETE THE SECCHI MONITORING FORM

In the lower left corner of your Secchi Monitoring Form, fill in the “Water Quality and Chlorophyll Sampling Programs” box, indicating the chlorophyll sample(s) you collected today, to what depth you collected the chlorophyll sample(s), how many mLs of lake water you filtered for each chlorophyll sample, and the date that the chlorophyll sample(s) will be shipped.

Water Quality and Chlorophyll Sampling Programs						
Indicate bottles collected	Bottle w/o Acid TSS/SS, Alkalinity, Chloride, Nitrate	Bottle w/Acid TP, TKN, Ammonia	Chlorophyll (a, b, c & pheophytin)			
			1 Liter Bottle	Sample Depth	Amount Filtered	
1	<input type="checkbox"/>	<input type="checkbox"/>	<input type="checkbox"/>		ft	ml
2	<input type="checkbox"/>	<input type="checkbox"/>	<input type="checkbox"/>		ft	ml
3	<input type="checkbox"/>	<input type="checkbox"/>	<input type="checkbox"/>		ft	ml
	<input type="checkbox"/>	<input type="checkbox"/>	<input type="checkbox"/>		ft	ml
	<input type="checkbox"/>	<input type="checkbox"/>	<input type="checkbox"/>		ft	ml

Date Mailed: _____

IL 532-0941 Rev. 09/12 WPC 388e Volunteers - Retain PINK copy

11. CHLOROPHYLL EQUIPMENT CLEAN-UP & STORAGE

See pages 86–87 of this Manual for chlorophyll sampling and filtering equipment care and storage instructions.

12. DISSOLVED OXYGEN/TEMPERATURE METER CARE & STORAGE

See pages 87–88 of this Manual for care and storage instructions for the dissolved oxygen/temperature meter provided to you.

13. HANDHELD ELECTRONIC DEPTH SOUNDER CARE & STORAGE

See page 89 of this Manual for care and storage instructions for the electronic depth sounder provided to you.

14. VAN DORN SAMPLER CARE & STORAGE

See Appendix B of this Manual for care and storage instructions for the Van Dorn water sampler.

Shipping the Water Sample Bottles

IMPORTANT NOTE: Remember to keep the water chemistry sample bottles in ice for at least 1 hour after collection and until you are ready to pack and ship the samples. To help keep the sample bottles cold during their transport to the lab, wait as late in the day as possible before you pack the sample bottles in your shipping cooler(s) and take them to UPS. Check with your local UPS Customer Center, UPS Store, or other authorized UPS shipping provider to find out when their latest UPS pick-up is, and plan your sample packing and travel to UPS accordingly (www.ups.com; 1-800-PICKUPS).

1. Remove any ice from your shipping cooler and use the blue ice packs provided to you. Make sure the caps on the sample bottles are closed tightly. Arrange the ice packs and bottles so that the ice packs are in contact with at least 2 sides of each bottle. Use as many ice packs as will fit in the cooler.

- **Small cooler** (used for shipping 2 sample bottles): Place a large and small ice pack on the bottom of the cooler. Lay the two sample bottles on their side on top of the large ice pack, then place another large and small ice pack on top of the bottles.



- **Large cooler** (used for shipping 4 to 8 sample bottles): Place a small and large ice pack on the bottom of the cooler. Arrange the bottles standing up between additional ice packs. Then place more ice packs on top of the bottles.



NOTE: If there is excess space between the top layer of ice packs and the lid, you may add some bubble wrap on top of the ice packs.



2. Insert the **blue** lab form into a reclosable plastic bag, seal the bag, and then place the bag inside the cooler on top of the top-most ice packs (or bubble wrap).
3. If one isn't already there, tape a note to the inside of the cooler's lid that says "Please return to: (your name and full mailing address, phone number)." Do not write on the cooler.



If you also collected samples for chlorophyll analysis, the chlorophyll sample filter packets are to be shipped along with the water sample bottles. See "Shipping the Chlorophyll Sample Filters" on the next page for additional instructions.

4. Securely tape the cooler shut with strapping tape wrapped completely around the cooler. Be sure to tape down the handle so it is not broken off during shipment.
5. Stick the pre-printed, postage-paid UPS shipping label* to the outside, top of the cooler. Sign and date the label in the lower right corner. Do not fill out the "Shipment From" section.

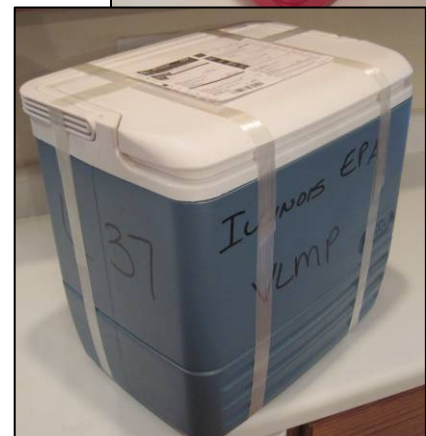

***NOTE:** All water sample bottles and chlorophyll sample filters are to be shipped to the **Illinois EPA Lab**,
825 N. Rutledge, Springfield, IL 62702
(ph: 217-782-9780).

Take the cooler to the nearest UPS Customer Center, The UPS Store, or other authorized affiliate. They will weigh the cooler and give you a copy

of the shipping document. Keep this document and use the tracking number to track your samples' journey to the lab.

IMPORTANT NOTE: The samples should be shipped the same day they are collected. If for some reason the samples cannot be shipped until the following day, keep the water sample bottles upright in a shallow ice bath in a cooler overnight (inside your home or office rather than in a hot garage or outbuilding) and until you are ready to pack and ship them the next day. Do not allow the bottles to become immersed in ice water. Keep chlorophyll sample filter packets rubber-banded to an ice pack and in a freezer overnight. Remember, these samples have a short holding time and should be shipped in a timely manner, and no later in the week than Wednesday (see the “When to Sample” section on page 45 of this Manual).

6. A few days after you ship your samples, the cooler and ice packs will be returned to you from the laboratory.

Open the cooler and make sure the bottles, chlorophyll sample filter packet(s), and lab sheets were removed by the lab. Remove all old tape and shipping labels. As necessary, rinse the inside of the cooler and the ice packs with tap water. Allow the cooler to air dry (with its lid open) before storing. Place the ice packs back in a freezer so they're ready for the next sample shipment.

7. If your cooler is not returned within 10 days, call your VLMP Coordinator for assistance.

Shipping the Chlorophyll Sample Filter(s)

IMPORTANT NOTES:

- It is important to freeze the foil-wrapped chlorophyll filter(s) within their reclosable baggie(s) immediately after filtering. After securing each baggie containing a foil packet to a frozen ice pack using rubber bands, place the ice pack(s) with the attached baggie(s) into a freezer for at least

1 hour and until you are ready to pack and ship them to the lab. If you do not have access to a freezer, sandwich the baggie(s) between two ice packs (you can use additional rubber bands to hold the two ice packs together, if needed), and keep the ice packs in a cooler and out of the sun.

- The chlorophyll sample filters are to be shipped in the same cooler with your water sample bottles.
- Ensure the chlorophyll baggie(s) end up being sandwiched between two ice packs in the shipping cooler.
- Include the **green** chlorophyll lab form(s) in the reclosable plastic bag along with the water sample lab form(s), seal the bag, and then place the bag inside the cooler on top of the ice packs (or bubble wrap).



Mailing the Dissolved Oxygen/Temperature Profile Forms

Ensure the top section of each Dissolved Oxygen/Temperature Profile form is filled out completely (name, date, time, etc.). In the Comments section, you may wish to include notes about the weather or unusual lake conditions while you were out monitoring. Mail the Dissolved Oxygen/Temperature forms along with your Secchi Monitoring form to your Coordinator. (You may want to make a photocopy of your Dissolved Oxygen/Temperature forms for your records before mailing.)

NOTES

Equipment Clean-Up, Care, & Storage

ALL Volunteers:

TIER 1 MONITORING EQUIPMENT

- ✓ **Secchi Disk:** Rinse off any mud or other debris on the Secchi disk and rope/survey tape. Wind the rope/survey tape around the dowel rod/dowel float. Make sure the survey tape is not creased or sharply folded, which can cause the tape to weaken and eventually break. Store the Secchi disk in a ventilated place out of direct sunlight. Occasionally check that the connectors attaching the rope or survey tape to the Secchi disk are tight.
- ✓ **Color Chart:** Store the Color Chart out of direct sunlight (so it doesn't fade).
- ✓ **Multi-plate Zebra Mussel Sampler:** If you have one of these samplers, regularly check during the monitoring season that the plates are screwed together tightly. At the end of the monitoring season, remove the multi-plate sampler from your lake. Wash the sampler thoroughly to remove all algae and debris, let it air dry, and store the sampler with your other VLMP equipment until the following spring.

Tier 2 & Tier 3 Volunteers:

WATER CHEMISTRY SAMPLING EQUIPMENT

- ✓ After every sampling trip, use tap water (never use soap) to rinse the half-gallon water sample collection bottle and its cap. **Allow the collection bottle to air dry** before replacing the cap and storing for the next sampling trip.
- ✓ If you have a Van Dorn sampler, see instructions in Appendix B.
- ✓ Keep all sample bottles upright in the storage box(es) provided to you during training. Store the bottles inside in a clean, cool, dry, and safe place out of the reach of children and pets. Remember there are bottles containing acid preservative that no one should touch except in connection with the VLMP.

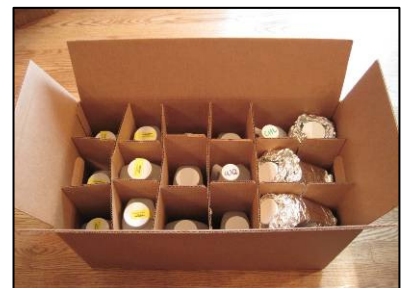

- ✓ Each time you receive your shipping cooler back from the lab, remove all old tape and shipping labels. As needed, rinse the inside of the cooler and the ice packs with tap water. Keep the cooler's lid open and allow it to air dry before storing. Place the ice packs back in a freezer so they're ready for the next sample shipment.
- ✓ At the end of the monitoring season:
 - Keep any leftover sample bottles upright in the storage box and store inside in a climate-controlled, safe place out of the reach of children and pets;
 - Rinse your shipping cooler(s) and ice packs with tap water, allow them to air dry completely, and store inside in a safe place for the winter.

The following spring, your VLMP Coordinator will provide additional instructions.

CHLOROPHYLL EQUIPMENT

- ✓ Remove the tubing from the filter flask's spout. Use tap water (never use soap) to rinse the filter flask, graduated cone, and both portions of the magnetic filter funnel. *(Do not rinse the tubing. We don't want moisture to get into the vacuum pump.)* Empty the wash bottle. **Allow everything to air dry** before storing the chlorophyll filtering equipment back in the plastic tote. Make sure the tote's lid is on tightly, and keep the tote in a clean, cool, and safe place out of the reach of children and pets.



- ✓ Rinse the half-gallon chlorophyll collection bottle and the solid and “with-hole” caps. **Allow the collection bottle to air dry** before replacing the solid cap and storing for the next sampling trip.
- ✓ Store the chlorophyll collection bottle and the brown-colored chlorophyll sample bottles in a clean, cool, and safe place out of the reach of children and pets.

- ✓ If necessary, rinse off the weighed bottle sampler and its rope, and allow to air dry before storing in a well ventilated place out of the sun.
- ✓ Each time you receive your shipping cooler back from the lab, remove all old tape and shipping labels. As needed, rinse the inside of the cooler and the ice packs with tap water. Allow the cooler to air dry (with its lid open) before storing. Place the ice packs back in a freezer so they're ready for the next sample shipment.
- ✓ At the end of the monitoring season:
 - Keep any leftover, brown-colored chlorophyll sample bottles in the storage box and store in a climate-controlled, safe place out of the reach of children and pets;
 - Remove any dust or debris that may have accumulated in or on your chlorophyll supply tote, keep any leftover filters and labels, and store indoors in a climate-controlled place out of the reach of children and pets;
 - Rinse your shipping cooler(s) and ice packs with tap water, allow them to air dry completely, and store inside in a safe place for the winter.
 - Rinse the weighted bottle sampler and its rope if necessary and allow to air dry completely, then store inside in a safe place for the winter.

The following spring, your VLMP Coordinator will provide additional instructions.

DISSOLVED OXYGEN/TEMPERATURE METER

After each monitoring trip:

- ✓ Disconnect the cable from the meter. Never store the meter connected to the cable.
- ✓ Rinse the shroud and probe with deionized or distilled water. If deionized or distilled water is not available, you may use tap water.
- ✓ **Allow the probe to air dry.**

- ✓ Arrange the cable and probe in the carrying case so that the cable is not sharply bent and the sensor cap (dark surface on the tip of the probe) is protected from damage.

IMPORTANT NOTES:

- If the sensor cap becomes scratched, it must be replaced by your VLMP Coordinator before you can use the meter again. Contact your Coordinator to arrange for the cap's replacement.
 - In all cases, the sensor cap must be replaced once a year. The Statewide or your Regional Coordinator will replace the sensor cap for you at the beginning of the monitoring season when you obtain your supplies for the season.
- ✓ Keep the carrying case open and allow the probe and cable to air dry.
 - ✓ Empty the water from the calibration flask and allow it to air dry.
 - ✓ Once everything is completely dry, return the calibration flask to the meter's carrying case and close the case, making sure the cable is not caught between the lid and the case bottom.
 - ✓ Store the case indoors, in a cool and safe place out of the reach of children and pets.



During the monitoring season:

- ✓ Check the battery life indicator in the upper right corner of the meter's screen regularly. If the indicator shows low battery life, replace the batteries before heading out onto the lake (4 AA alkaline batteries required). New batteries should also be used at the beginning of every monitoring season. While out on the lake, turn off the meter between monitoring sites to conserve battery life.

At the end of the monitoring season:

- ✓ Remove the four AA batteries from the meter. Do NOT store the meter over the winter with the batteries installed.

HANDHELD ELECTRONIC DEPTH SOUNDER

- ✓ During transport and use, take care to protect the transducer (nose) end of the depth sounder from damage.
- ✓ If the depth readings seem erratic or if no depth reading is displayed, try changing the battery (one, 9 volt battery required).

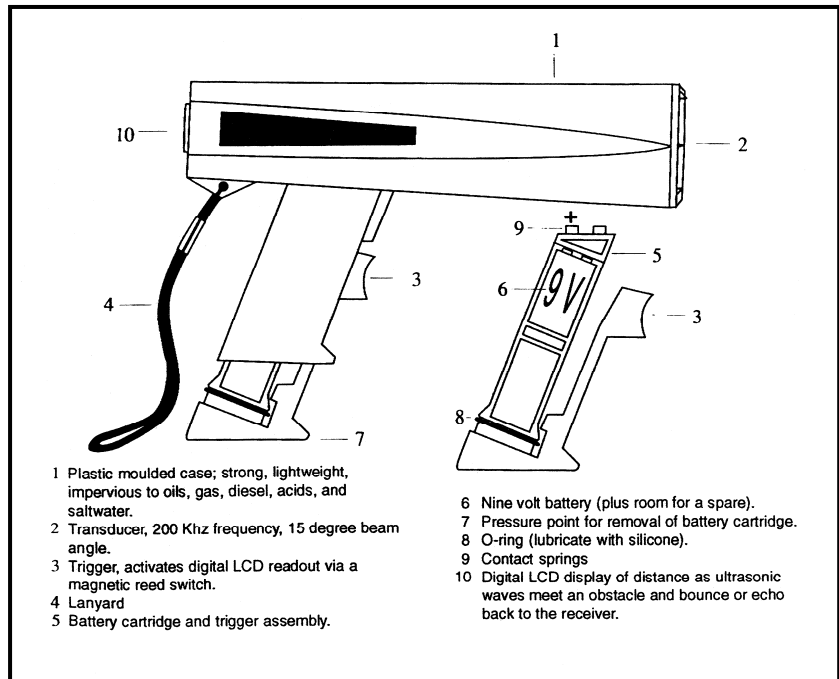

The battery is in the handle, within a waterproof cartridge. To remove the battery cartridge from the handle, hold the unit upside down and simultaneously pull the trigger and apply pressure to the bottom of the battery case. If very tight, use a thin-blade screwdriver inserted between the battery case and bottom of the handle, using care not to damage the surfaces. The case will crack if forced. After installing a new battery, firmly push the cartridge back into place.

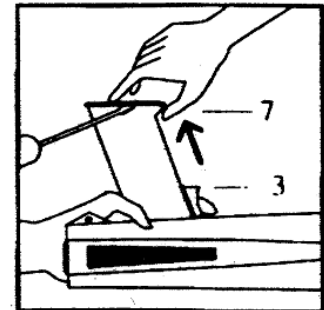

CAUTION: The unit is not waterproof when the battery cartridge is out of the handle. Do not expose the unit to water or dampness when the battery cartridge is out. Change the battery in a protected place where there is no danger of splashing or exposure to inclement weather. If the cartridge gets wet or water gets into the handle, leave the unit in a warm, dry place with the battery cartridge out and allow to air dry thoroughly before reassembling.

- ✓ For cleaning the outside of the depth sounder, use water, a mild detergent, and a soft cloth.
- ✓ At the end of the monitoring season, remove the battery from the depth sounder for overwinter storage.

Chemical Safety Information

SULFURIC ACID PRESERVATIVE

The following is chemical safety information regarding the handling of sulfuric acid (the liquid preservative found in the water sample bottles with yellow tape across the cap). Keep these bottles upright in the storage box(es) provided to you during training. Store the bottles indoors in a cool, dry, and safe area out of the reach of children and pets.



HEALTH HAZARD & FIRST AID INFORMATION

May cause severe burns, and may be fatal if swallowed.

EYE CONTACT: Immediately flush eyes with gentle but large stream of water for at least 15 minutes, lifting upper and lower eyelids occasionally. Call a physician immediately.

SKIN CONTACT: Immediately flush skin with plenty of water for at least 15 minutes while removing contaminated clothing and shoes. Wash clothing before reuse. Excess acid on skin can be neutralized with a 2% solution of bicarbonate of soda (baking soda). Call a physician immediately.

INGESTION: DO NOT INDUCE VOMITING. Drink large quantities of water. Call a physician immediately.

INHALATION: Remove to fresh air. If not breathing, give artificial respiration. If breathing is difficult, give oxygen. Call a physician immediately.

SPILLS AND CLEANUP INFORMATION

If spilled on clothing, upholstery, carpet, etc., cover area with sodium bicarbonate (baking soda). Wear gloves, eye, and skin protection. Mix and carefully add water to form a slurry. Scoop up neutralized slurry and flush down the drain with plenty of excess water. Rinse clothing thoroughly under running water, and wash before rewearing.

Record Keeping

Keeping a copy of your data helps you track your lake monitoring activities. It also safeguards your data in the event that a Secchi Monitoring form, laboratory form, or Dissolved Oxygen/Temperature Profile form is misplaced or lost in the mail.

Each Secchi Monitoring form is composed of three carbonless sheets: a top (white) copy, a middle (yellow) copy, and a bottom (pink) copy. After you have completed filling out a Secchi form, tear off the bottom, pink copy to keep for your records (double check that your writing came through dark enough to read on the pink copy). Then mail the white and yellow copies to your VLMP Coordinator in one of the pre-addressed, postage-paid envelopes provided.

If you have access to the Internet, enter your monitoring data on-line into Illinois EPA's VLMP database (see the *When You Return Home* section on page 39 of this Manual).

You also may wish to transcribe your Secchi data to a Personal Record of Observations form (found after page 92 of this Manual). This form allows you to view the entire year's Secchi transparency data on one sheet.

If you collected water samples, you may wish to make a photocopy of your laboratory form(s) before you ship the form(s) to the lab with your samples.

If you recorded dissolved oxygen/temperature measurements, you may want to make a photocopy of your Dissolved Oxygen/Temperature Profile form(s) before you mail the original form(s) to your VLMP Coordinator. Mail the Dissolved Oxygen/Temperature form(s) in the same envelope with your Secchi Monitoring form.

Personal Record of Observations Form

Following this page is a Personal Record of Observations form. This is for your use—it provides a place to record one season’s worth of Secchi monitoring observations all together on one sheet. Additional copies of this form are available from your Coordinator. This form also is available electronically on the VLMP website (<http://www.epa.state.il.us/water/vlmp>).

Water Chemistry Laboratory Forms & Shipping Labels

Following this page is a pocket for storing a one-season supply of blue “water chemistry” laboratory forms and a one-season supply of UPS shipping labels *(for Tier 2 and Tier 3 participants only)*.

This page intentionally blank for
double-sided printing.

Chlorophyll Laboratory Forms & Shipping Labels

Following this page is a pocket for storing a one-season supply of green “chlorophyll” laboratory forms *(for Tier 3 and select Tier 2 participants)*.

This page intentionally blank for
double-sided printing.

HACH HQ Series Meters – LDO Probe Calibration Procedure (Water–Saturated Air Method)

1. Add approximately ¼–½ inch of water (tap water is OK) to the 250 mL “calibration” flask provided with the meter.
 - **NOTE:** The exact volume of water is not critical. There should be enough water in the flask to completely coat the inside of the flask when shaken (Step #2), but not too much that the probe touches the water when inserted (Step #5).
 - **TIP:** If you add the water to the calibration flask the night before and let it sit overnight, the meter will calibrate more quickly since the water will have reached room temperature.
2. Screw the cap on the calibration flask and shake vigorously for 2 to 3 minutes.
3. Connect the probe's cable to the meter by aligning the connectors and tightening the locking ring.



4. While holding the the probe's shroud, carefully unscrew the locking ring from the shroud. Gently slide the shroud and locking ring off the probe, being careful not to scratch the sensor cap (dark surface on the tip of the probe).



5. Unscrew the calibration flask's cap, and carefully place the sensor end of the probe into the flask. The probe will fit snugly; do not force the probe down any further into the flask. Ensure that the probe stands up straight in the flask and does not tip over. **Let the probe sit in the flask for 5 to 10 minutes** to allow a humid environment to form in the flask.

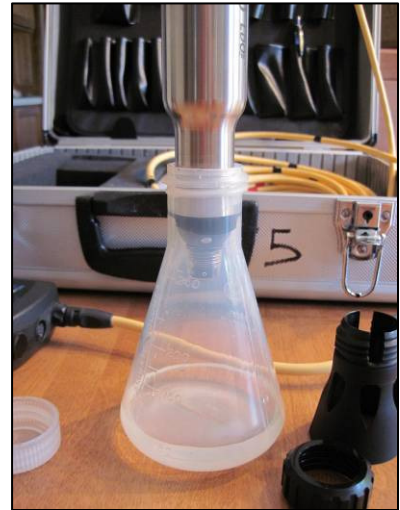

- **IMPORTANT NOTE:** If the flask tips over and the probe gets wet, or you notice that the probe tip has water droplets on it, then you must very gently dry the probe tip using a soft cloth (such as a clean t-shirt or soft terry cloth; do **NOT** use a paper towel). Then reinsert the probe and let it sit for 5–10 more minutes.

6. Turn on the meter.

- **NOTE:** If upon turning on the meter you see the message “Dry the probe. Place it in water-saturated air and press read,” skip to Step 8.

Power ON/OFF button



7. Press the BLUE Button (under “Calibrate” on the display screen)

The following message will appear: "Dry the probe. Place it in water-saturated air and press read."

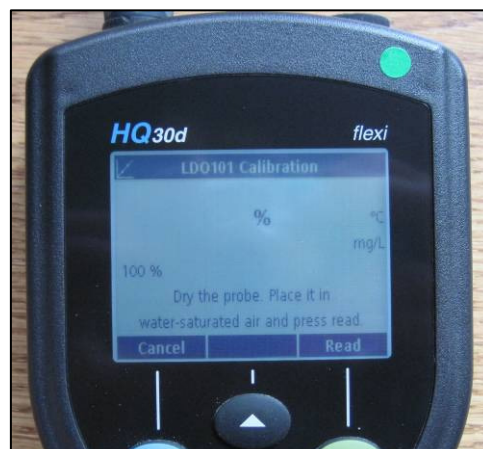

- **IMPORTANT NOTE:** If the probe tip remained dry after placing it in the flask, you can ignore this message. If the flask tipped over and the probe got wet, or you notice that the probe tip has water droplets on it, go back to the **IMPORTANT NOTE** under Step #5.

8. Press the GREEN Button (under “Read” on the display screen)

A “Stabilizing” bar will be displayed while the meter measures the temperature every 60 seconds. Once the temperature is stable, the meter will measure the dissolved oxygen (D.O.) concentration. When the calibration is complete, the meter will “beep,” the Stabilizing bar will be replaced with a padlock symbol, and the message “Calibration Complete” will be displayed on the screen.

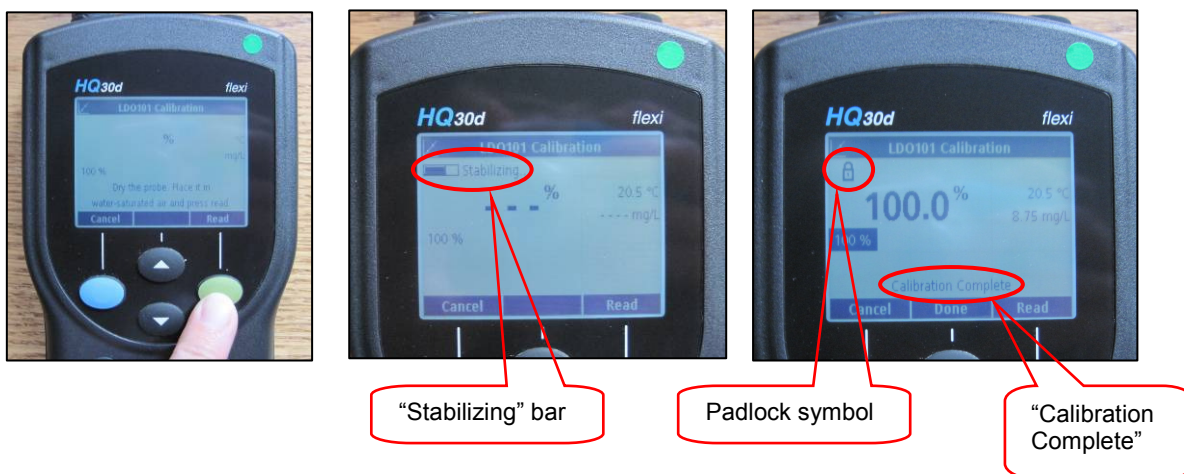

9. Press the UP ARROW Button (under “Done” on the display screen)

This ends the calibration. The instrument displays a “**Calibration Summary**” screen that provides the % change in the slope relative to the current factory calibration as well as other information specific to the user calibration: type of D.O. standard (100% water-saturated air), the temperature, and atmospheric (barometric) pressure during the calibration. **Record this atmospheric pressure**—displayed in mm Hg (millimeters of mercury) in the lower right corner of the display screen—**next to “Barometer Reading”** on your D.O./Temperature Profile forms.

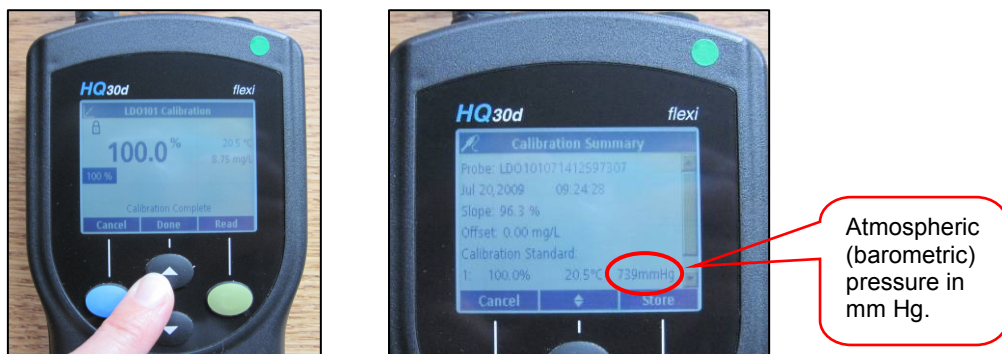

10. Press the GREEN Button (under “Store” on the display screen)

This accepts and stores the user calibration and returns the display to the measurement screen. You will know that the calibration is current when an “OK” is displayed next to the graph symbol in the upper left corner of the screen. If there is a “?” instead of an “OK,” the calibration is not current, and you must conduct the calibration procedure again.

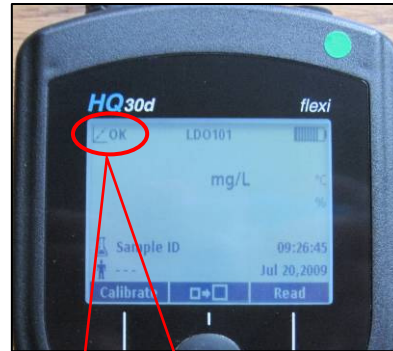

Graph symbol and “OK” indicate that the calibration is current

11. Turn the meter off. Carefully remove the probe from the calibration flask. Carefully slide the locking ring and shroud back onto the probe, being cautious not to scratch the sensor cap (dark surface on the tip of the probe). Hand-tighten the locking ring around the shroud. Return the meter, cable, and probe to the carrying case for transport to the lake.



Dissolved Oxygen/Temperature Profile Monitoring Forms

Following this page is a pocket for storing a one-season supply (plus some extras) of “Dissolved Oxygen/Temperature Profile” forms for recording dissolved oxygen and temperature measurements (*for Tier 3 and select Tier 2 participants*).

This page intentionally blank for
double-sided printing.

Appendix A

Online Database Secchi Form Entry

(including D.O./Temperature Profile Data
Upload Instructions)

NOTES

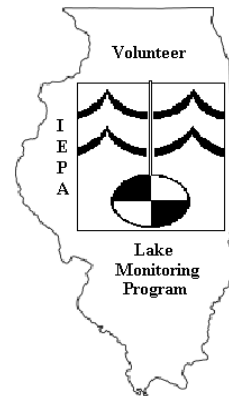

ONLINE DATABASE SECCHI FORM ENTRY

<http://dataservices.epa.illinois.gov/waBowSurfaceWater>

← **Online Database
Secchi Form Entry
Address**

Need Help? [Email the Volunteer Coordinator or View FAQs](#)
[Download DO/Temp Profile Template](#)

POWERED BY
CSLA

Application Options:
[Add Secchi and DO/Temp Sample Data](#) | [Search for Data](#)

Home

Since 1981, citizen volunteers, the Illinois EPA, and area-wide planning commissions have been working to monitor the quality of Illinois' lakes through the Illinois Volunteer Lake Monitoring Program (VLM). This cooperative effort provides information on many more lakes than could be otherwise monitored by the state agency staff. The volunteers have learned much about their lakes, and a substantial database has been established from information they have collected. The data is routinely used by lake scientists, planners, consultants, and the volunteers themselves for a wide variety of purposes.

Browser Requirements:
The following are requirements needed for using the VLM Web Application

Internet Explorer 6, 7, 8
Javascript Enabled
Allow Poppups from this Site. (*this is not for advertisement purposes but for informational reminder messages.)
Recommended Screen Resolution of 1024 by 768 or higher.

*To change or check any of the browser settings above, please refer to your browser's documentation or desktop display settings.

If you are using Internet Explorer v8 and are having issues with the above Get Started Menu you may [Click Here](#) to see how to toggle compatibility mode.

Homepage View

**Under Application
Options:**

**Click on Add Secchi and
DO/Temp Sample Data**

Need Help? [Email the Volunteer Coordinator or View FAQs](#)
[Download DO/Temp Profile Template](#)

POWERED BY
CSLA

Application Options:
[Add Secchi and DO/Temp Sample Data](#) | [Search for Data](#)

Home > [Get Started \(Hover Here\)](#) > [Volunteer Lake Monitoring Program](#) > [Add Secchi and DO/Temp Sample Data](#)

Select a Lake to Enter Sample Results:

Altamont New (RCJ) - EFFINGHAM Go

Lake Selection Page

**Select your lake from the
drop-down list.**

Notice that the lake selection drop-down has the lake name, lake code, and county.

It is possible to have several lakes in the Program with the same name. For example: To the right, you can see there are two Spring Lakes and three Sunset Lakes in the Program. To help differentiate, we added the lake code and county.

After selecting your lake, click on Go to the right of your selection.

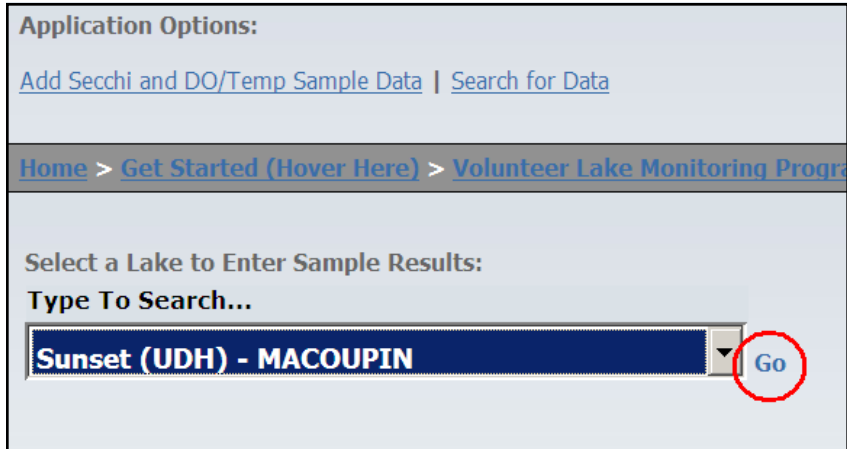
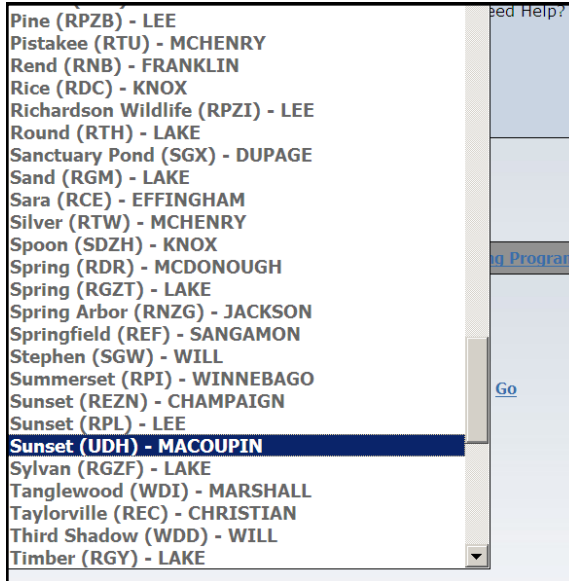

Login Page

Login using the email address you provided on your Registration Form. Your password was supplied in a letter mailed to you after registering in the Program.

Contact your coordinator if you cannot find your password.

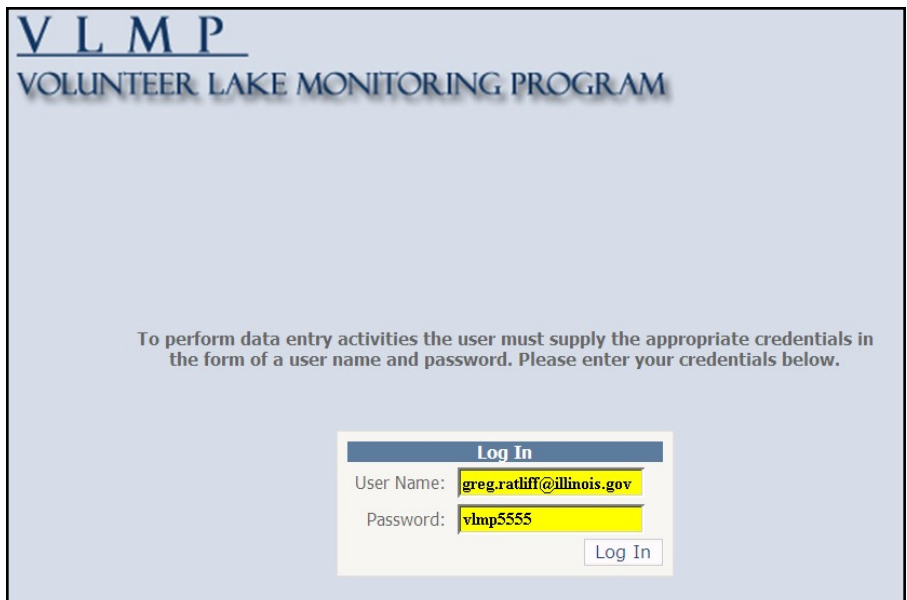

Data Entry Page

Verify that you have selected the correct lake.

You are currently entering Secchi sampling results for Sunset (UDH) - MACOUPIN

Monitoring Event

Sample Date:

General Weather Conditions:

Amount of Rain (inches): Wind Direction: Cloud Cover: Waves:

Lake Level is by inches Gage Reading (inches): Aquatic Plant %: Volunteer Hours:

Monitoring Event Section

Fill in information for the Monitoring Event as completely as possible. This information comes directly from your Secchi Monitoring Form. This first section contains general lake information.

The single most important information in this section is the date. Without a date to tie the event to, the data gathered is impaired and may not be useful.

Monitoring Event

Sample Date:

General Weather Conditions:

Amount of Rain (inches): Wind Direction: Cloud Cover: Waves:

Lake Level is by inches Gage Reading (inches): Aquatic Plant %: Volunteer Hours:

Observations:

Unusual Weather Conditions and Noticeable Lake Changes Since Last Monitoring:

Additional Observations/Aquatic Plants Present:

Lake/Watershed Management:

Aquatic Exotics:

Select an exotic from the drop-down and click the arrow to add. For more information visit: [Illinois-Indiana Sea Grant](#)

Exotic Type:

Selected Aquatic Exotics:
 [Add](#)

[Remove Selection](#)

[Remove Selection](#)

Monitoring

Sample Date:

General W

Amount of Rain (inches):

Lake Level is by inches

Observations:

September, 2010

Su	Mo	Tu	We	Th	Fr	Sa
29	30	31	1	2	3	4
5	6	7	8	9	10	11
12	13	14	15	16	17	18
19	20	21	22	23	24	25
26	27	28	29	30	1	2
3	4	5	6	7	8	9

Today: September 30, 2010

NOTE: For exotics, use the drop-down, then hit the grayed arrow button next to the drop-down box to add that exotic to the Selected Aquatic Exotics box.

Volunteers Currently Assigned to (your lake).
Click a box(es) to assign volunteer(s). At least one volunteer must be assigned or you will receive an error when station data is entered. If you do not see a volunteer listed, you can add them on the right hand side of this section; however, at least one box must be checked or an error will occur.

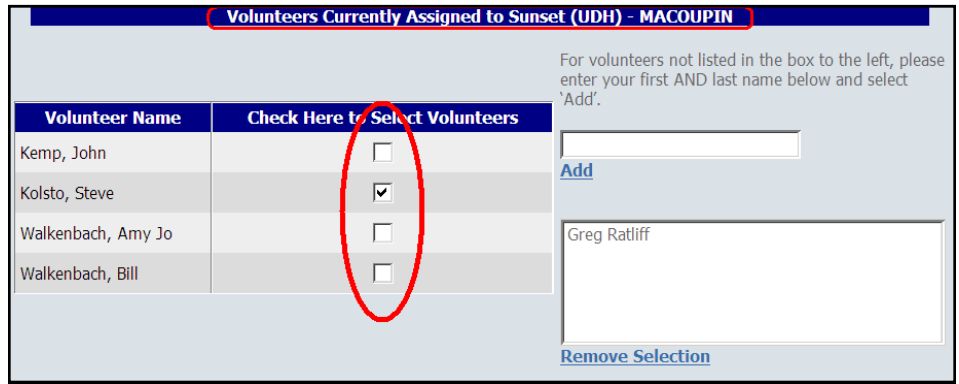

Contact your coordinator if you do not find a name to check. Only supplying names in the text boxes will cause an error to occur in data submittal.

DO/Temp Profile File Upload

For those who monitor dissolved oxygen and temperature profiles, only.

First, download a DO/Temp Profile Template and save it to your hard drive where you can find it after each sampling event.

You can also download an example for use in filling out the excel spreadsheet.

Save each event's spreadsheet with an unique file name that you can identify when uploading on the site.

HINT: It is best to already have this done before logging in to the website for each event.

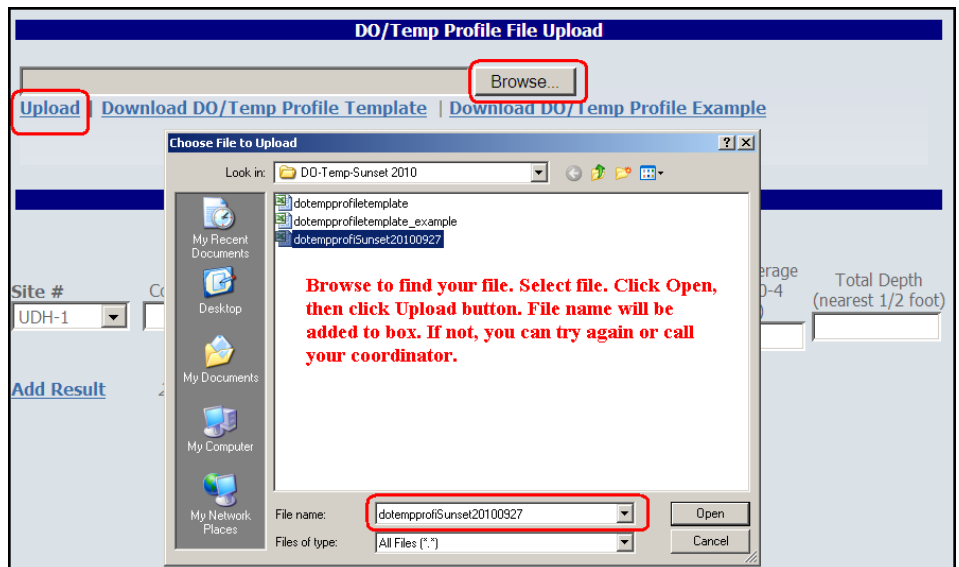
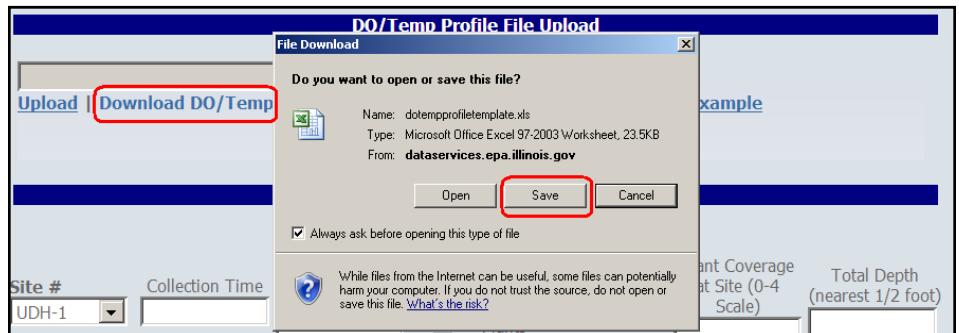
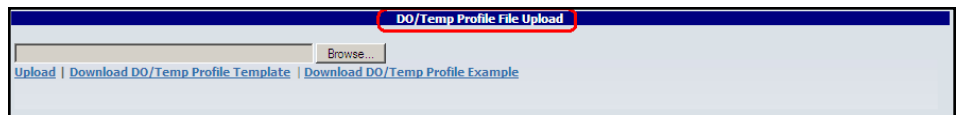

Secchi Results

Site # Collection Time Secchi Depth (nearest inch) Secchi Visible on the Bottom Secchi Hidden by Aquatic Plants Color (1-20) Plant Coverage at Site (0-4 Scale) Total Depth (nearest 1/2 foot)

[Add Result](#) 24HR Format

Secchi Results.

Select a site # from the dropdown list and input your data in each of the blocks. Only click the little boxes under **Secchi Visible on the Bottom** and **Secchi Hidden by Aquatic Plants**, if the answer is yes.

After filling in all the appropriate data for a give site #, click on **Add Result**.

The page will refresh, now showing the information you entered in a table format.

Select the next Site # on the dropdown list and add data for that site. Remember to **Add Result** for the last site to enter before clicking on **Finished**.

Review the data entered. You may delete or edit the Secchi information you have entered by clicking on the corresponding **Edit** or **Delete** button.

When you are satisfied with the data entered, click on **Finished**.

Secchi Results

Site # Collection Time Secchi Depth (nearest inch) Secchi Visible on the Bottom Secchi Hidden by Aquatic Plants Color (1-20) Plant Coverage at Site (0-4 Scale) Total Depth (nearest 1/2 foot)

[Add Result](#) 24HR Format

Secchi Results

Site # Collection Time Secchi Depth (nearest inch) Secchi Visible on the Bottom Secchi Hidden by Aquatic Plants Color (1-20) Plant Coverage at Site (0-4 Scale) Total Depth (nearest 1/2 foot)

UDH-1
UDH-2
UDH-3

24HR Format

Site #	Collection Time	Secchi Depth (nearest inch)	Secchi Visible on the Bottom	Secchi Hidden by Aquatic Plants	Color	Plant Coverage at Site	Total Depth (nearest 1/2 foot)		
UDH-1	15:35	26	No	No	13	0	15.5	Edit	Delete

[Finished](#)

Important: If site numbers are missing from the dropdown list, contact your coordinator.

Secchi Results

Site # Collection Time Secchi Depth (nearest inch) Secchi Visible on the Bottom Secchi Hidden by Aquatic Plants Color (1-20) Plant Coverage at Site (0-4 Scale) Total Depth (nearest 1/2 foot)

[Add Result](#) 24HR Format

Site #	Collection Time	Secchi Depth (nearest inch)	Secchi Visible on the Bottom	Secchi Hidden by Aquatic Plants	Color	Plant Coverage at Site	Total Depth (nearest 1/2 foot)		
UDH-1	15:35	26	No	No	13	0	15.5	Edit	Delete
UDH-2	15:45	20	No	No	17	1	10.5	Edit	Delete
UDH-3	15:55	13	No	No	15	3	6	Edit	Delete

[Finished](#)

After clicking on **Finished**, a popup will appear giving you one last chance to confirm your data. If all data are entered correctly, click **Submit**.

Clicking submit will **finalize** your data entry session. Please ensure all data entered below is accurate before clicking submit. If you find any errors you may click cancel and correct them. Upon clicking submit an email confirmation will be generated and sent to you. Once this operation is complete you will be returned to **add additional results**. If you are **done entering results** after clicking submit **you may select Logout** to end your session or **select another menu option from the drop down menu above**.

Sample Date: 09/30/2010 Aquatic Plants: No Selection Volunteer Hours: Amount of Rain in the past 48 hours:
 Wind Direction: None Cloud Cover: No Selection Waves: No Selection
 Lake Level Is: No Selection Lake Level Measure: Gauge Reading:
 Observations:
 Other Information:
 Management:

Aquatic Exotic(s) Present

Volunteer(s) Assisting During Monitoring Trip
 Kolsto, Steve

Other People Assisting

Secchi Result(s)

Site #	Collection Time	Secchi Depth (nearest inch)	Secchi Visible on the Bottom	Secchi Hidden by Aquatic Plants	Color	Plant Coverage at Site	Total Depth (nearest 1/2 foot)
UDH-1	15:35	26	No	No	13	0	15.5
UDH-2	15:45	20	No	No	17	1	10.5
UDH-3	15:55	13	No	No	15	3	6

To add another sample to Sunset (UDH) - MACOUPIN please check the box before selecting Submit.

After submitting your data, the lake selection page will come up, giving you the opportunity to enter data for another sampling event on the same or other lake.

Need Help? [Email](#) the Volunteer Coordinator or [View FAQs](#).
[Download DO/Temp Profile Template](#)

POWERED BY

Application Options:
[Add Secchi and DO/Temp Sample Data](#) | [Search for Data](#)

[Home](#) > [Get Started \(Hover Here\)](#) > [Volunteer Lake Monitoring Program](#) > [Add Secchi and DO/Temp Sample Data](#)

Select a Lake to Enter Sample Results:

Altamont New (RCJ) - EFFINGHAM

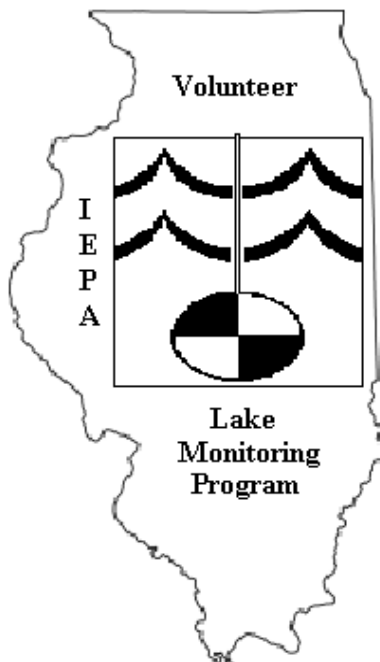

If you experience problems,

Contact VLMP Help at:
epa.vlmphelp@illinois.gov

Or contact your regional coordinator.



Appendix B

Van Dorn Water Sampler – Use, Care & Storage

In the Tier 3 program, a near-bottom water sample is collected at Site 1 (and potentially at other sites on a lake-specific basis) using a Van Dorn sampler. The sampler is comprised of a clear plastic cylinder with a rubber stopper or end cap on each end, with an external trip mechanism attached to a rope. After the end caps are set to their open position, the Van Dorn is lowered into the lake to the desired depth. A weighted messenger is then sent down the rope, causing the end caps to snap shut, thereby capturing the water at that depth in the sampler. The Van Dorn is then raised back into the boat and water is released through a valve to fill sample bottles.

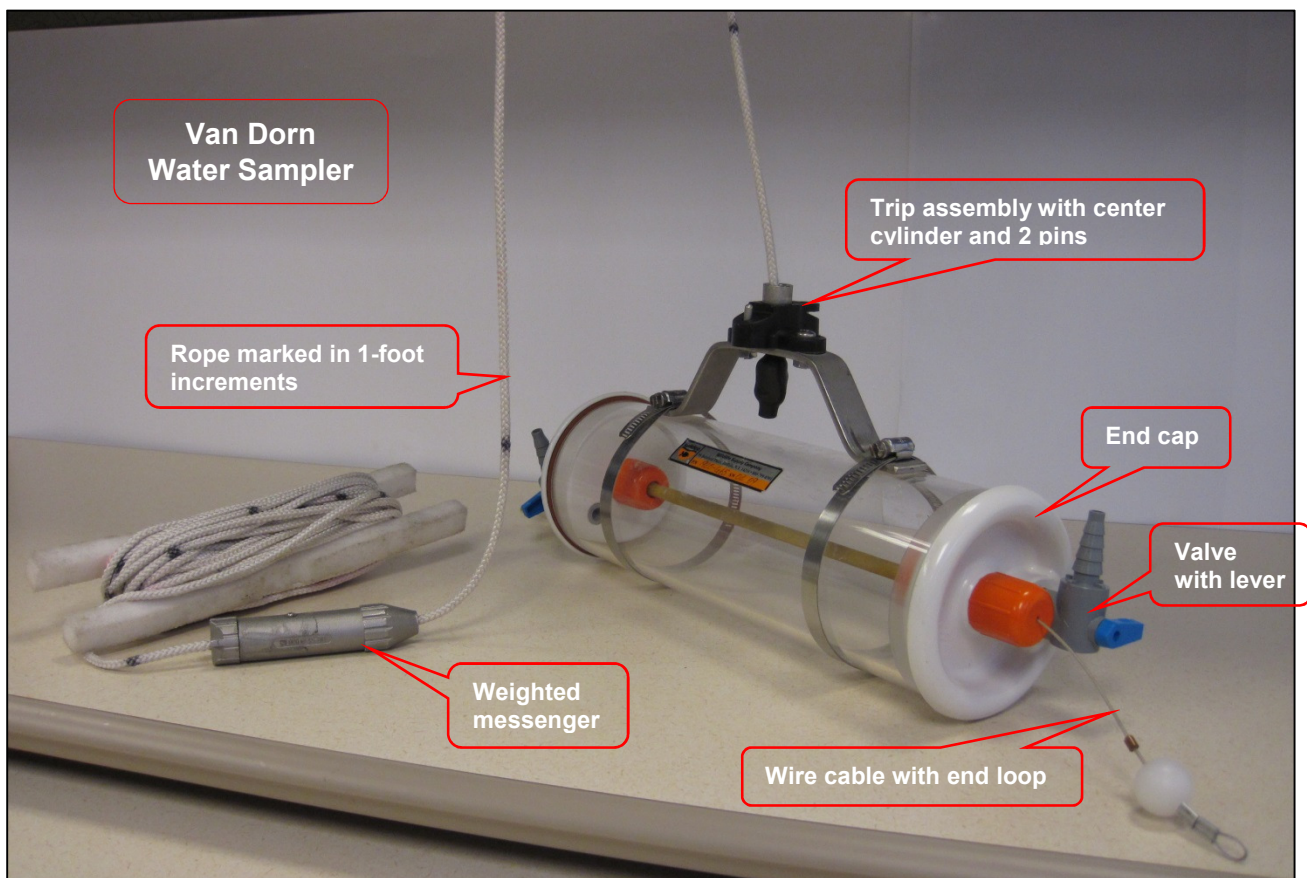

Collect the near-bottom water sample as follows:

1. Check the water depth again using a hand-held or boat-mounted electronic depth sounder. The water sample is to be collected at 2 feet above the lake bottom.
2. Ensure the valve on each end cap of the Van Dorn is in the closed position.



Valve is in closed position when the blue lever is at a 90° angle from the valve opening

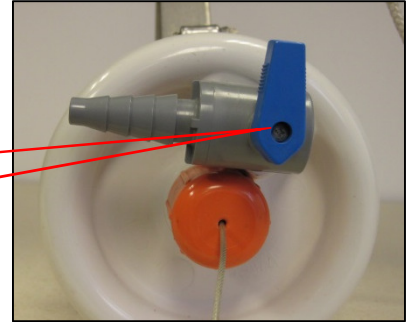

VERY IMPORTANT: When handling the Van Dorn, do NOT touch the inside of the sampler, the inside of the end caps, or the valve tips with your hands or fingers to help avoid contamination of sample water.

3. Set the end caps to the open position:
 - a. Push down on the center cylinder on the trip assembly with your thumb.
 - b. Pull the wire cable attached to one of the end caps and position the end loop into the “covered” pin slot.
 - c. Release the center cylinder on the trip assembly and ensure that the pin rises up into the loop and secures the wire cable. One of the end caps is now in its open position.
 - d. Pull the other wire cable attached to the other end cap and position the end loop over the other pin. Now both end caps are in their open position.

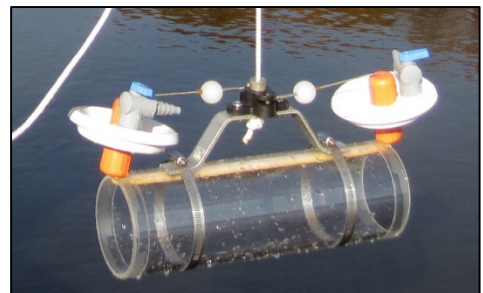

NOTE: The end caps are attached to each other with a taut rubber tube, so you'll need to pull hard.

CAUTION: Be aware that when the trip assembly is triggered, the end caps snap shut very quickly and with great force. To avoid injury, keep fingers away from the open ends of the Van Dorn in case the trip assembly is prematurely triggered and the end caps snap shut.

4. Rinse the Van Dorn on the “rinse” side of the boat:

Hold the weighted messenger in one hand and the rope in the other hand. Lower the Van Dorn into the water a couple feet and release the weighted messenger. The messenger will slide down the rope and trip the end caps closed. Raise the Van Dorn out of the water. Over the lake, open both end valves and rotate the Van Dorn from side to side so that water flows through each valve. When the Van Dorn is about half empty, you can pull one of the wire cables attached to an end cap to empty the remaining water. Remember to do this over the lake and not in your boat!



5. Repeat steps 2 and 3 (setting the end caps in their open position).

6. Move/turn to the “collect” side of the boat.

7. Hold the weighted messenger in one hand and the rope in the other hand above the messenger.

NOTE: The rope is marked in 1-foot increments.

8. Slowly lower the Van Dorn to the “2 feet above the lake bottom” sample depth by parlaying the rope through the weighted messenger and counting each foot-marker as it nears the water surface. Do not let the sampler touch the lake bottom.

9. Slowly move the Van Dorn from side to side a few times to help ensure that water from the desired sample depth is within the sampler.

10. Make sure the rope is in a vertical position.

11. While continuing to hold the rope above the weighted messenger with one hand, use your other hand to “throw” the weighted messenger down the rope.

12. A “click” might be heard when the messenger trips the end caps closed, and you may see bubbles rising.

13. Slowly raise the Van Dorn to the surface.

14. Open one valve over the lake to discharge a little water to clear any potential contamination.



Valve is in open position when the blue lever is in line with the valve opening

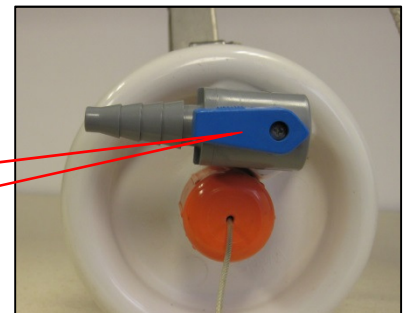

15. Using the same valve, fill each sample bottle to near its neck. Open the opposite valve to release vacuum pressure. Be careful not to overfill the sample bottles.



16. Recap the sample bottles tightly and immediately place the bottles into a cooler in ice.

17. Discard any remaining water in the Van Dorn on the “rinse” side of the boat.

18. Return the Van Dorn to its carrying case.

Van Dorn Care and Storage

After your sampling trip, rinse the Van Dorn with tap water and a small amount of diluted Liqui-Nox cleaning solution (provided by your Coordinator) in the following manner:

- Make sure the valves are closed. Open one end cap. Pour a small amount (capful) of diluted Liqui-Nox solution into the Van Dorn. Add some tap water. Close the end cap. Rotate and shake the Van Dorn to coat all the inside surfaces of the Van Dorn. (There will be a lot of foam/bubbles). Run the foamy water through both valves. Rinse the inside of the Van Dorn thoroughly with plenty of tap water, and let plenty of water run through both end valves, until no bubbles remain.

Remember, do not touch the inside of the end caps or Van Dorn body with your fingers to prevent contamination.

- After rinsing, set the end caps in their open position and let the Van Dorn air dry overnight indoors in a protected area. The next day or when thoroughly dry, close the end caps, leave the valves in their open position, and place the Van Dorn in its case for storage, indoors and out of the reach of children and pets, until the next lake sampling session.



NOTES

Appendix C

Hydrilla Hunt! Initiative



Hydrilla is recognized as one of the world's worst weeds. It can grow an inch per day and form dense mats of vegetation at the water surface, seriously impacting our desirable native plants, sport fishing, native wildlife, waterfront property values, and recreational uses. Within the past few years, hydrilla has been discovered in Wisconsin, Indiana, and Iowa, so it could arrive in Illinois very soon.

Hydrilla Hunt! is a collaborative effort with the Northeast Illinois Invasive Plant Partnership, Chicago Botanic Garden, and Lake County Health Department – Lakes Management Unit. As a VLMP participant, you are in a key position to help keep a sharp eye out for this nasty invader.

How Can You Help?

You can help discover hydrilla in three easy steps — here's how!

1. Learn to identify hydrilla

Leaves

Reproduced below are portions of the Hydrilla ID Sheet for Illinois. (A laminated Hydrilla ID Sheet is provided in the front pocket of this Training Manual, and an electronic version can be downloaded from this webpage: <http://www.niipp.net/hydrilla/additional-resources/>). Hydrilla leaves are arranged in a "whorl" (a series of leaves that grow around the stem at the same height). Also shown are two look-alike plants: Brazilian elodea (another invasive plant), and American elodea (a desirable native plant). If this all seems a bit complicated, just remember that if the plant has more than three leaves per whorl — and the leaves have noticeably toothed edges — then you have probably found hydrilla!

INVASIVE



Michael J. Grodowitz, U.S. Army Engineer Research and Development Center



HYDRILLA

Hydrilla verticillata

INVASIVE

- a. whorls of **more than 3** leaves
- b. leaves often have **visibly toothed** edge
- c. leaf vein often has **small visible spines**

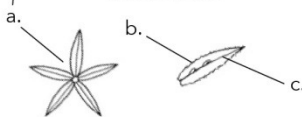

NATIVE



Christian Fischer, www.commons.wikimedia.org



BRAZILIAN ELODEA

Egeria densa

INVASIVE

- a. whorls of **more than 3** leaves
- b. leaves do **not** have visibly toothed edge
- c. leaf vein is **smooth** underneath

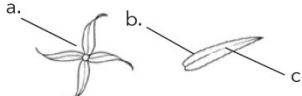

Illustrations: Center for Aquatic and Invasive Plants, University of Florida



Paul Skawinski, Aquatic Plants of the Upper Midwest

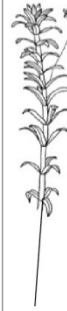

AMERICAN ELODEA

Elodea canadensis

NATIVE

- a. whorls of **exactly 3** leaves
- b. leaves do **not** have visibly toothed edge
- c. leaf vein is **smooth** underneath

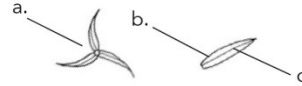

In the photos to the right, notice the toothed edges of hydrilla leaves, as well as the whorls of more than three leaves.



photos courtesy Robert Vidéki, Doronicum Kft., Bugwood.org

Tubers

Hydrilla produces tubers that grow in the sediment of lakes and streams. Each tuber can produce a new plant. The tubers are less than 1/2 inch long and can remain alive for many years.

NOTE: Brazilian elodea and American elodea do not produce tubers.



2. Keep a sharp lookout for this plant at your local lake, pond, or river!

3. Report what you've found!

If you think you have found hydrilla, please use your phone or digital camera to take 1 or 2 close-up photos of a plant stem on a light-colored background (then discard the plant fragment in the trash). Please email your photos to Hydrilla Hunt! at HydrillaHunt@niipp.net and to your VLMP Coordinator. Include a brief description of where the plant was found (e.g., county, lake, boat ramp, etc.). Hydrilla Hunt! staff will acknowledge receipt of your e-mail and let you know what they see. If you're not able to send a digital picture, e-mail Hydrilla Hunt! staff and they will contact you.

For More Information...

... including additional photos of hydrilla and resources (e.g., ID cards, posters), see the Hydrilla Hunt! website at <http://www.niipp.net/hydrilla/>.

UNWANTED!



HYDRILLA COULD IMPACT YOU



Hydrilla is an invasive aquatic "superweed" that's been found recently in Indiana and Wisconsin. Our enjoyment of fishing, swimming, and boating will be dramatically affected if it gets into Illinois' lakes and rivers.

Hydrilla can grow an inch a day and produce a dense mat of stems on the water surface. Early detection of hydrilla could save Illinois millions of dollars in control costs.



www.niipp.net/hydrilla

Take a Hydrilla Hunt! card and keep it handy as you enjoy Illinois' waterways. If you think you've found hydrilla, please let us know right away!

TAKE A HYDRILLA HUNT CARD!



IDENTIFICATION
HYDRILLA VERTICILLATA

- a. whorls of more than 3 leaves
- b. leaves often have visibly toothed edges
- c. leaf veins often have small visible spines

Notice the toothed edges of hydrilla leaves, as well as the whorls of more than three leaves.

Think you have found hydrilla? Email us a picture of the plant stem placed on a light-colored background. If you're unable to send a digital picture, email us and we will contact you.

Hydrillahunt@niipp.net

HELP IDENTIFY THIS PLANT EARLY ON WHEN POPULATIONS ARE STILL SMALL ENOUGH TO ERADICATE AND MANAGE!

Appendix D

Identifying & Reporting Harmful Algal Blooms in Illinois

Harmful Algal Blooms in Illinois

Blue-green algae are microscopic organisms that occur naturally in Illinois lakes and streams. Despite their name, blue-green algae are actually types of bacteria known as Cyanobacteria. When certain conditions are present, such as high nutrient and light levels, these organisms can reproduce rapidly. This dense growth of algae is called a bloom. While blooms can occur at any time of year, they are primarily a concern during the months of July through September. Adverse health effects could occur when waters exhibiting a blue-green algal bloom are swallowed, come in contact with skin, or when airborne droplets containing toxins are inhaled while swimming, boating, waterskiing, tubing, bathing or showering. Pets are also at risk when allowed to drink or swim in surface water containing a blue-green algae bloom. Health effects can include asthma-like symptoms, abdominal pain, vomiting, diarrhea, rashes, or severe neurotoxicity depending on the exposure level and type of toxin present in the water.

Identifying Harmful Algal Blooms

When blue-green algae reproduce quickly and bloom, there are physical signs. The blooms can look like green paint spilled into the water, thick puffy foams on the surface of the water (scums), or swirling colors beneath the surface of the water. A blue-green algal bloom will coat an object when it is dipped into the water. Long strands of green algae, duckweed, and filamentous macro-algae are sometimes confused with blue-green algal blooms (see photos below). Blue-green algae blooms also have distinct smells. They can smell grassy or septic, and in some cases the smell can cause nausea. These algal blooms can accumulate near the shoreline of lakes, and can move based on wind and wave action in the lake.

Photos of some blue-green algae blooms:



Commonly mistaken for blue-green algae:

Duckweed

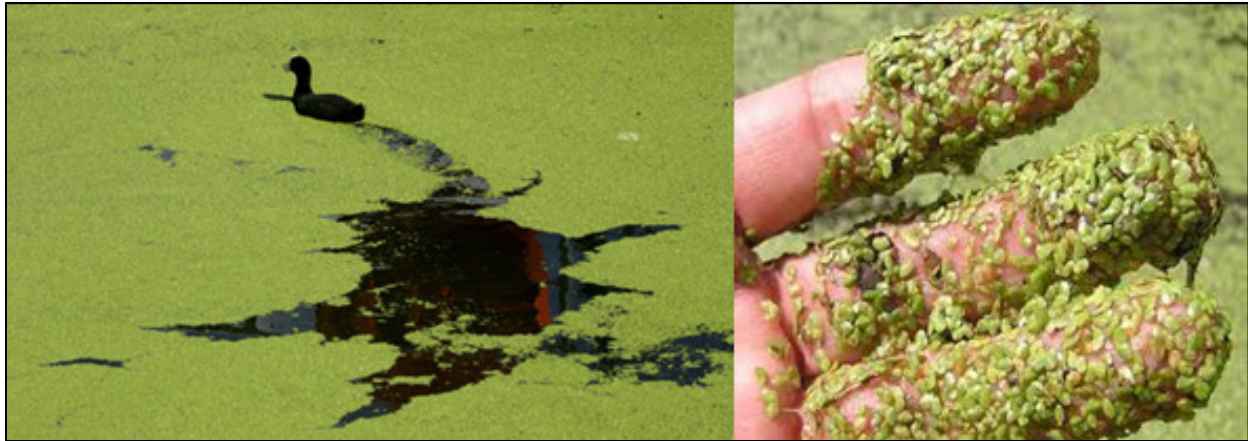

Filamentous algae



Reporting a Harmful Algal Bloom

If you suspect that blue-green algae are blooming on your lake, or a public lake you've visited, please report it to Illinois EPA.

- As soon as possible after seeing the bloom, fill out a "Bloom Report Form." You can fill out a form online at Illinois EPA's HAB website (<http://www.epa.state.il.us/water/algal-bloom/forms/bloom-report-form.pdf>) and save it to your computer, or request a hardcopy from your VLMP Coordinator. (A hardcopy from which you can make photocopies is also

provided at the end of this section.) Fill out as much of the Bloom Report Form as possible.

NOTE: You may contact Illinois EPA or your VLMP Coordinator and request that they file the Bloom Report Form on your behalf by giving them all of the essential information, including photos.

If you would like information and updates on the condition of the bloom you reported, make sure your contact information is provided on the Bloom Report Form.

- Take photographs of the algae. At least 1 photo should be a close-up of the algae scum and at least 1 photo should be taken to include more of the bloom area to help identify the location of the bloom or scum on the lake.
- Submit electronic versions of the Bloom Report Form and photos to Illinois EPA at EPA.HAB@illinois.gov and to your regional VLMP Coordinator.

What Happens Next?

If the report and photos indicate that a bloom or scum has the potential for producing toxins, a HAB responder will be sent to investigate the bloom as soon as possible. This could be an Illinois EPA employee or a VLMP Coordinator. The HAB responder will investigate, provide technical assistance and, if necessary, collect samples.

- A HAB Responder will use the Bloom Report Form to locate the bloom, and may contact you for further information. The Responder may collect a microcystin sample. If so, the Responder may analyze the microcystin sample using a qualitative test kit (which provide immediate results) and provide results to the reporter.
- The remaining sample may also be sent for further quantitative analysis (with a longer turn around for results). Again, if levels are of concern, results will be provided to the reporter.

NOTE: With this information in hand, the lake owner or association, at their discretion, may choose to close or post an advisory at the lake warning people of the elevated microcystin toxin levels.

- Follow-up qualitative samples may be taken, on a site specific basis, to provide the owner or association with information pertaining to when to lift or extend the closure or advisory for the lake.

Interpreting Results

The table below outlines the likelihood of an immediate health effect from recreational surface water use in the presence of varying concentrations of microcystin toxin. Long-term exposure effects are not available.

Relative Probability of Acute Health Effects (Advisory Level)	Microcystin-LR (ug/L)	Total Cyanobacteria (cells/mL)
Low	<10	<20,000
Moderate	10-20	20,000-100,000
High	20-2,000	100,000-10,000,000
Very High	>2,000	>10,000,000
Reference: The World Health Organization (WHO) guidance values for the relative probability of acute health effects during recreational exposure to microcystins, based on information presented in Chorus and Bartram (1999); and Graham and others (2009).		

Safety

Extreme caution should be taken in the case of any exposure to a possible Harmful Algal Bloom. People should avoid direct skin contact with the water, inhaling droplets of the water, and ingesting any water. When working near or investigating blooms, safety equipment including gloves, carpenter's mask, waders, goggles, and personal flotation device is recommended.

If you come into contact with a potential HAB, wash your skin and any equipment with soap and tap water immediately after exposure. Do not use lake water that

looks clear for washing. Even lake water that appears not to have algae can have toxins associated with it. Do not allow pets or children to come into contact with the water, because even the clear-looking water surrounding the scum may be contaminated with toxins.

For More Information...

...see Illinois EPA's Harmful Algal Blooms and Algal Toxins website at <http://www.epa.state.il.us/water/algal-bloom/index.html>.

Bloom Report Form

Please provide information about the potential blue-green algae bloom observed. Information can be entered into this electronic form and saved onto your computer. Please save and e-mail a completed copy of this form to EPA.HAB@illinois.gov. Please include at least two digital photographs (one close up & one landscape photo to show the surroundings) as additional e-mail attachments.

Bloom Location:

Water Body Name:	Date bloom observed:
County:	Drinking water source(yes, no, unknown):
Publicly owned lake(yes, no, unknown):	Digital photos attached(yes, no):

Report Completed By:

Name:	Organization:
Title:	Phone #:
	E-Mail:

Are you a VLMP volunteer/coordinator (yes, no):

Bloom Description and Sampling Information:

Please describe the location of the bloom in the water body (e.g. center of lake, boat dock, beach, etc.):

Did you notice any colors in the water column (yes, no)?

Please describe the color(s) you see:

Was there a foul smell associated with the bloom (e.g. septic, rotten, fishy, earthy, etc.)?

Please describe:

Please estimate the size (sq. feet) of the bloom:

Can you see a surface scum (an accumulation of algae at the surface) or algae floating near the water surface (algae at the surface can look like grass clippings, green /blue thick foam, spilled paint (yes, no, uncertain)?)

Is the bloom near a public beach, boat ramp or marina (yes, no - please specify name)?

Is the bloom near a public water supply intake (yes, no, unknown – specify water system name if known)?

Were samples taken (yes, no)?

If yes, what types of samples, when and where were they collected, and where were they sent for analysis, results, etc?

Do you know if other water quality information is available (please specify)?

Agency Use Only:

Action taken, if any (advisory posted, owner notified, factsheet handed out, etc.)?

